

# Coolblade BTD

12÷35 kW



## General

The Coolblade range is specifically dedicated to Data Centres, in applications characterised by "hot aisle" and "cold aisle" layouts or in systems with containment and separation of the hot part from the cold part.

## Configurations

DX: Direct expansion air conditioning unit for coupling to external motocondensing unit.

CW-DW: Direct expansion air conditioning units air cooled, with DC-Inverter scroll compressor.

ED+: Chilled water air conditioning unit.

## Strengths

- ▶ Available in chilled water (CW - DW), direct expansion with (ED+) and without (DX) compressor on board version
- ▶ High heat removal on small footprint
- ▶ Axial and radial fan configuration
- ▶ Very high efficiency (increased in axial fan configuration)
- ▶ Installation flexibility
- ▶ Full redundancy option for Tier IV datacenter (DW version)





---

<b>APPLICATION</b>	<b>3</b>
<b>CONFIGURATION</b>	<b>5</b>
<b>SPECIFICATIONS</b>	<b>5</b>
<b>DESCRIPTION OF ACCESSORIES</b>	<b>9</b>
Other accessories	14
ELECTRICAL ACCESSORIES	15
<b>TECHNICAL SPECIFICATIONS</b>	<b>24</b>
COOLBLADE DX	24
COOLBLADE ED+	25
COOLBLADE CW-DW	26
<b>ELECTRICAL DATA</b>	<b>27</b>
<b>NOISE LEVELS</b>	<b>28</b>
<b>REFRIGERANT DIAGRAMS</b>	<b>30</b>
COOLBLADE DX	30
COOLBLADE ED+	30
<b>HYDRAULIC DIAGRAMS</b>	<b>31</b>
COOLBLADE CW-DW	31
<b>OPERATING LIMITS – COOLBLADE DX</b>	<b>32</b>
<b>OPERATING LIMITS – COOLBLADE ED+</b>	<b>33</b>
<b>OPERATING LIMITS – COOLBLADE CW-DW</b>	<b>34</b>
<b>Dimensional diagrams</b>	<b>35</b>
COOLBLADE DX	35
COOLBLADE ED+	43
COOLBLADE CW-DW	51
<b>INSTALLATION TIPS</b>	<b>62</b>





# APPLICATION

The Coolblade range has been designed for use in Data Centres that require insertion of cooling units in an in-row configuration, that is, inserted between racks. These are therefore devices expressly made for insertion in a hot aisle/cold aisle configuration. Their operation can be concisely described as follows: the racks draw in fresh air from the front and expel hot air from the back using the fans supplied with the equipment contained inside them. The racks are arranged in opposing rows, so that they are facing the same aisle; the result is the creation of alternately cold (in front of the racks) and hot aisles (behind the racks).

In conventional systems, primary cold air is usually supplied from under a raised floor, by precision air conditioning units positioned on the outer edge of the room or just outside it ("external" or "room" air conditioning).

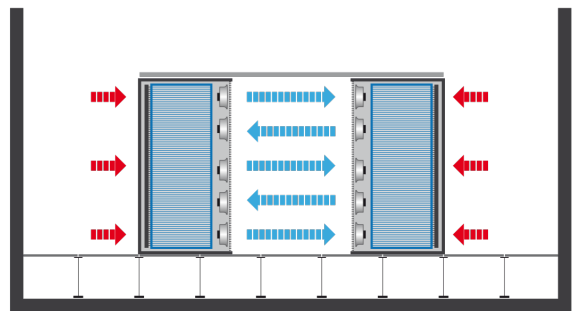
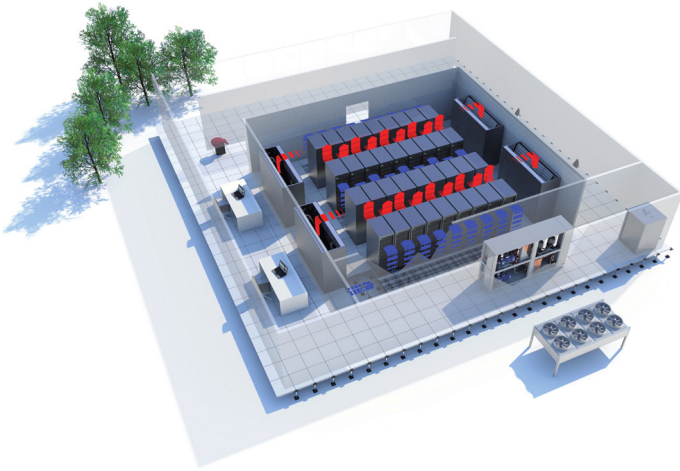
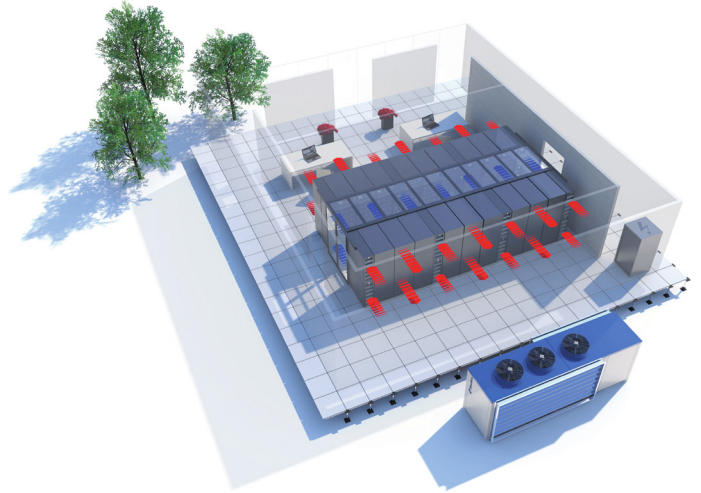

Coolblade units manage the heat load using various methods and strategies, which can vary according to the specific installation method and the type of cooling system; in any case, with reference to the ASHRAE guidelines (TC9.9 /2011).

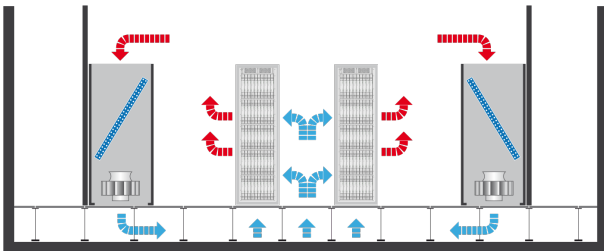

But Coolblade units draw in hot air directly from the hot aisle and put it, cooled, into the cold aisle. A sufficient number of Coolblade units are installed alongside and in between the racks to cover the design heat load, usually with the addition of one or more redundant units to guarantee continuity of cooling in all situations.

Maximization of energy efficiency is obtained with so-called containment, through which the hot and/or cold areas are isolated, thereby preventing any air bypass or recirculation between the two sections.

It should also be emphasised that this type of application does not require a raised floor for air distribution, or alternatively a moderately high raised floor for just power or refrigerant distribution.

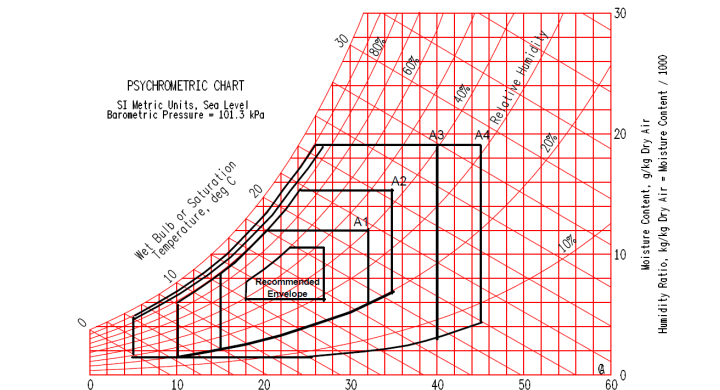

A feature common to all versions is the presence of variable speed fans with electronically commutated (EC) motors, which can modulate based on the return temperature (from the hot aisle); depending on configurations, it is also possible to modulate the cooling capacity based on the return temperature or, alternatively, choose to keep the supply temperature constant in the cold aisle (this last functionality is valid only for chilled water or direct expansion systems with modulation of cooling capacity).

The fans are available in axial version, with front air supply, and in radial version, with side air supply (from one side or both sides).



Direct expansion units, provided with evaporating coils, are designed to be connected to an external condensing unit, which can indifferently be provided with a variable speed or fixed speed compressor. It is possible to use condensing units provided with expansion valve (which therefore feed the internal unit with a liquid/gas mixture) and condensing units without expansion valve (which feed the internal unit with subcooled high pressure liquid); in the second case, the expansion valve can be installed on the Coolblade DX unit.

The unit can control the external condensing unit through a modulating 0-10V or on/off signal, and receive an alarm signal from it.

Instead Coolblade ED+ units are fitted with DC Scroll Brushless compressor directly on board. The units include as well electronic expansion valve and are designed for connections to remote air cooled condensers. The units can have as well (as accessory) the fan speed control for the remote air cooled condensers, to grant the best system operation.

For chilled water applications, Coolblade are also available as CW (Single circuit chilled water circuit with or without valve) and DW (Double chilled water circuits with or without valves). This last version can be extremely interesting for all those Data Centers which require the highest redundancy. In fact, Coolblade DW are extremely compact units with 2 hydraulic circuits completely independent. Within all the available accessories the solution with dual power supply with automatic changeover allows to design a unit **TIER IV ready**.

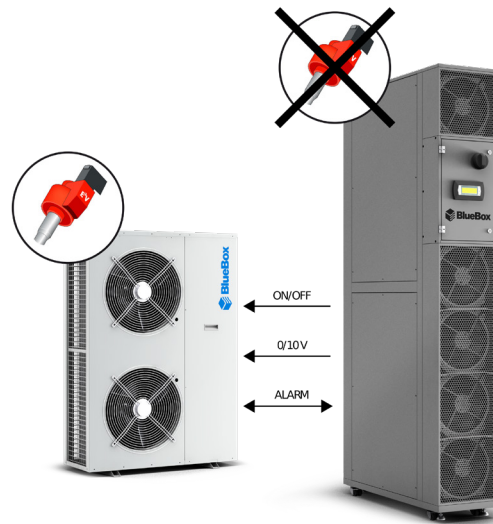

Example of connection with Blue Box condensing unit, provided with expansion valve.

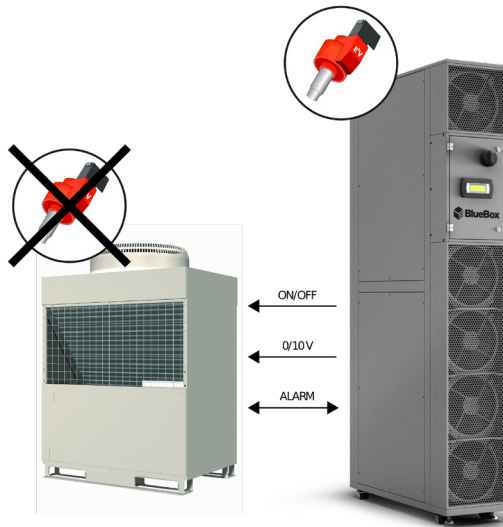

Example of connection with condensing unit not provided with expansion valve.



Example of connection between Ed+ unit and air cooled remote condenser.

# CONFIGURATION

Configuration example:

Coolblade BTD	DX	A	12	L
Coolblade BTD	DX	A	12	L
1	2	3	4	5

1	Series	Coolblade BTD
2	Type	<b>DX</b> : direct expansion without compressor on board <b>ED+</b> : direct expansion with compressor on board <b>CW</b> : chilled water with single hydraulic circuit <b>DW</b> : chilled water with double hydraulic circuit
3	Fan Section	<b>A</b> : Axial Fans, Frontal Air Delivery <b>R</b> : Radial Fans, Lateral Air Delivery <b>RR</b> : Radial Fans, Right Air Delivery <b>RL</b> : Radial Fans, Left Air Delivery
4	Size	<b>12</b> : Cooling Capacity at nominal catalogue conditions
5	Cabinet Variation	<b>&lt;none&gt;</b> : depth 1000 mm <b>L</b> : depth 1200 mm

# SPECIFICATIONS

## DIMENSIONS AND CONFIGURATION

The dimensions of the Coolblade units are 300x1000x2000 (width x depth x height, expressed in mm) or 300x1200x2000 ("L" versions). All units are provided with air filters at the inlet, copper coils with aluminium finning, fans, electrical control panel and electronic microprocessor controller.

Air is always sucked in from the back, filtered and cooled, and then expelled from the front thanks to the action of the fans positioned downstream of the exchange coil, evenly distributed over the entire height of the unit. Depending on the type of fans, air is expelled from the front or side into the cold aisle, thereby ensuring the best air distribution according to the application.

## STRUCTURE

The structural frame is fabricated from polished sheet-steel with oven-baked epoxy polyester powder coating. The removable panels are also made of polished sheet-steel with oven-baked epoxy polyester powder coating, and internally insulated with open-cell matting (fire reaction class A2 according to EN13501). The colour is RAL9005 (black), with textured finish. Unpainted internal panels and infills are made of hot dip galvanised sheet-iron.

The units are provided with wheels to make handling easier and adjustable feet for final positioning. There are threaded inserts in the upper part to make them easier to fix to adjacent racks.

All the materials making up the unit are recyclable and CFC-free.

## FANS

The units are equipped with 3, 4 or 5 (depending on size) variable speed electric fans with directly coupled electronically commutated (EC) motor. Each fan is provided with integrated thermal overload protection.

The fans are installed on the front, downstream of the handling coil and can be accessed from the front of the unit even after installation, without having to take the unit out of the row of racks.

The unit design allows a quick fan replacement without the need of stopping the entire cooling, granting the full availability (Hot Swappable).

Available as an option are axial fans, which combine excellent efficiency and energy saving qualities, and radial fans, which allow a higher air flow rate than the axial version and the possibility of directing the supply air to the side of the unit.

Air flow is constantly monitored by a differential pressure switch, which signals an alarm condition when there is no flow.

## AIR FILTERS

The non-regenerable air filter is class ISO Coarse 30% (according to ISO 16890; G1 - EN779) and is designed to minimize head loss while maintaining an adequate level of filtration. The filters are pleated and contained in a 100mm-thick galvanised sheet-iron frame. They can be accessed from the back of the unit for maintenance operations.

The condition of the filters is constantly monitored by a differential pressure switch that signals when they are excessively fouled.

## CHILLED WATER HANDLING COIL AND HYDRAULIC CIRCUIT (CW and DW units)

The Coolblade CW and DW units are provided with handling coils with copper tubes and high turbulence aluminium fins, with hydrophilic coating.

A stainless steel condensate drip tray is positioned under the handling coil. The drain connection is from the bottom of the unit, unless a condensate booster pump (option) is requested, in which case the drain is plugged.

The CW units are provided with a single hydraulic circuit, without control valves in the basic version. Optionally available is a three-way valve with modulating servo control (0-10V control); or a two-way valve (for variable flow rate systems). The hydraulic connections can be carried out indifferently from the bottom or the top in units without valves; they are carried out from the bottom or, on request, from the top for units with valves.

The DW units are provided with a dual hydraulic circuit (a single finned pack coil with two interlaced circuits) without valves in the basic version. Optionally available is a three-way modulating valve (0-10V control) for each circuit; or a two-way valve (again, for each circuit). Each circuit can individually supply the full cooling capacity when the other circuit is not in operation. The controller installed on the unit also allows both circuits to be used at the same time, thereby supplying a higher cooling capacity to quickly satisfy any load peaks or temporary rises in water temperature.



---

## EVAPORATING HANDLING COIL AND REFRIGERANT CIRCUIT (DX units)

The Coolblade DX units are provided with handling coil with small-section copper tubes, specifically designed for use with refrigerant R410A, and high-efficiency aluminium fins with hydrophilic coating.

The refrigerant circuit includes shut-off valves for gas and liquid and two 5/16" service outlets for each side. The refrigerant connections can be carried out indifferently from the top or the bottom.

If the external condensing unit is not provided with expansion valve, the electronic expansion valve integrated in the Coolblade unit and managed directly by the installed electronic controller is available as option.

## REFRIGERANT CIRCUIT (ED+ units)

The refrigerant circuit comprises:

- liquid receiver
- Oil Separator on the delivery;
- Electronic Expansion Valve;
- solenoid valve for shutting off the refrigerant liquid
- Refrigerant liquid flow indicator;
- solid cartridge freon filter;
- safety valve;
- high pressure safety pressure switch with manual reset;
- low pressure switch with automatic reset
- on-off valves for external connections
- copper refrigerant pipes with anti-condensation insulation on the suction line;
- Pipe taps on suction and delivery side and charging valve on liquid side;

## EVAPORATOR COIL

The evaporator coils are finned coil, with copper tubes and aluminium fins with hydrophilic surface treatment. The fin profile is specially designed to prevent carry-over of condensation even at high through speeds. The coils are optimized for use with refrigerant R410A.

A stainless steel condensation collection basin is installed at the base of the coil, complete with fitting for drain and siphon.

## COMPRESSORS

The compressors are "twin rotary" (size 13) or "scroll" (size 21) with invertercontrolled brushless DC motor, operating with R410A. The compressors are provided with integrated thermal overload protection.

The compressor motor control driver is provided with integral electronic protection against overtemperature, overcurrent, over or under-voltage with absence of one or more phases.

The electronic control of the inverter is provided with automatic soft-start system and continuous control of the compressor curve to prevent and correct its use beyond the maximum allowed limits.

The refrigerant connections can be carried out indifferently from the top or the bottom.

## ELECTRICAL CONTROL PANEL

The electrical control panel is provided with an automatic circuit breaker and an isolation transformer for supplying power to the electronic controller, based on a microprocessor board and a display.

The wiring for the power supply and the field signals can be carried out indifferently from the top or the bottom, through suitable provision on the top or on the base of the unit.

The microprocessor controller inside the electrical control panel is provided with the following functions/features:

- Display of the return air temperature.
- Display of the supply temperature (on all the direct expansion units and on the chilled water units if the valve is present).
- Display of the incoming water temperature (only chilled water units).
- Display of the fan speed.
- Alarm signalling on two levels (serious alarm and minor alarm).
- log recording of the last 100 alarms.
- Display of the status of controlled devices.
- Display of the status of inputs and outputs of the microprocessor.

The electrical control panel is accessible from the back of the unit. It's fitted on two rails which allows to easily extract it, in case any kind of maintenance is needed on it.

The following potential-free contacts are supplied in the terminal board as standard:

- remote ON/OFF;
- serious alarm;
- minor alarm (message).

## BLUE THINK DATA

The Blue Think Data software fully incorporates the know-how and expertise of Swegon-Blue Box in Data Cooling applications. Blue Think Data is developed and constantly updated in-house through a continual improvement process.



Blue Think Data was conceived for the best functionality of the various units and systems installed in multiple machines, and at the same time it guarantees the highest safety level for both the components and application.

Blue Think Data incorporates the following key functions:

- control of return temperature;
- control of delivery temperature; (only for units with variable speed compressor or modulating chilled water valve)
- delivery temperature restriction;
- control of either relative or absolute humidity in the return line (only applies to units with the necessary sensor and/or humidifier);
- multiple solutions for ventilation control (with modulating fans and their options);
- integrated condensation control (where the relevant options have been selected);
- advanced alarm management: recording of 100 alarms in the memory, division of alarms into two categories (minor and serious alarms), smart automatic reset;
- auto restart after a voltage failure;
- function for quick restart (only if the Black Out Restart option has been selected);
- function for absorption limitation, which is implemented either via the setting of a limit absorption value or via an external digital request signal (only if the relevant options have been selected);
- integrated clock for timer-controlled switch-on/off and setpoint variation according to time bands;
- password-protected levels of access to parameter setup pages, protection against undesired tampering or tampering by unauthorised/non qualified staff;
- multi language interface, which the operator can select in real time;
- management of multiple locally networked units (up to 32) for integrated and optimised operation (if the corresponding option has been selected).

The graphic interface was designed for immediate feedback on the operating condition as well as for easy and efficient access to the various functionalities.



The standard unit offers the following control system interfaces, which are always included and active:

- a Modbus RS485 serial port for reading and writing purposes;
- a RJ45 port for IP communication, including a reading and writing Modbus TCP/IP, available as standard.

Supervision via WEB is always available with the RJ45 port. When the machine IP address is queried via web browser from any computer connected to the same local network to which the units are linked, access can be gained to the unit web page (password-protected access).

This solution is especially convenient and efficient to view the machine status or to perform maintenance. The solution does not require any dedicated software or hardware and it gives access to a set of graphs which are launched to monitor the trends of the main operating parameters of the unit in real time (temperature, humidity, air flow rate, etc.).



## HARDWARE

The operating hardware consists of the following elements:

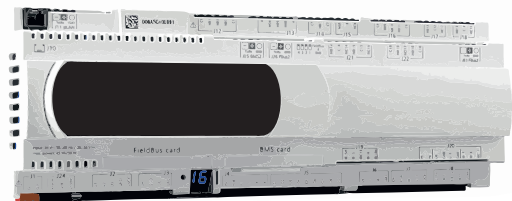

input/output boards including a 32-bit, 100 MHz microprocessor, with a 128-Mbyte non-volatile (FLASH) memory, 90Mbyte of which are available as file storage, and a 16 Mbyte data memory (RAM). Three different board sizes are used to optimise the number of inputs and outputs with respect to the application;



a humidifier-specific I/O board (which is therefore only fitted if this option is selected) communicating with the master board in serial mode;



a driver for the electronic expansion valve (where this option is selected) to pilot the electronic valve and integrate its data and functions in the machine. Communication with the master board is in serial mode.



The graphic terminal is a 4.3" touch screen panel. The electronic technology featured and the 65.000 colour display help manage high quality images and advanced functions. The touch screen panel is also designed for easier man-machine interaction as it makes screen browsing much more user-friendly.

The display is also supplied with a LED bar featuring different message-associated colours. The machine status can be viewed at any time without having to go close to the display.

Another innovative feature is the front position of the USB outlet for easier access without the use of specific tools.

<b>Type</b>	LCD TFT
<b>Resolution</b>	480 x 272 Wide
<b>Display active area</b>	4.3", diagonal
<b>Colours</b>	67 K
<b>Back-lighting</b>	LCD - Lifetime 20k hrs @ 25 °C
<b>Touchscreen</b>	Resistive
<b>System LED indicators</b>	8-colour notification bar

## STANDARD FEATURES

In addition to what was described in the previous sections, the standard features of the Coolblade units include:

- Adjustable support feet.
- Wheels to facilitate handling.
- Air flow alarm.
- Dirty filter alarm.
- Water sensor (anti-flood). (only for Coolblade CW-DW-DX)
- Thermal overload protection (internal) for each fan.
- Packaging in wooden crate with pallet.
- Divisible pallet to facilitate the positioning operation.

## TESTING

Leak tests and functional tests are carried out at the factory.

Units ED+ are supplied with refrigerant circuit charged with nitrogen, oil charge in the compressor and in the separator.

# DESCRIPTION OF ACCESSORIES

## HYDRAULIC ACCESSORIES

### PSC Condensate booster pump

Allows any condensate formed on the cooling coil and collected in the condensate drip tray to be boosted up to a hydrostatic head of 6m. Recommended in all cases where the hydraulic connections are carried out exclusively from the top.

All sizes Main specifications

- Length: 160 mm
- Width: 43 mm
- Height: 34 mm
- Power supply: 230 V - 1 ph - 50/60 Hz
- Max. absorption: 16 W

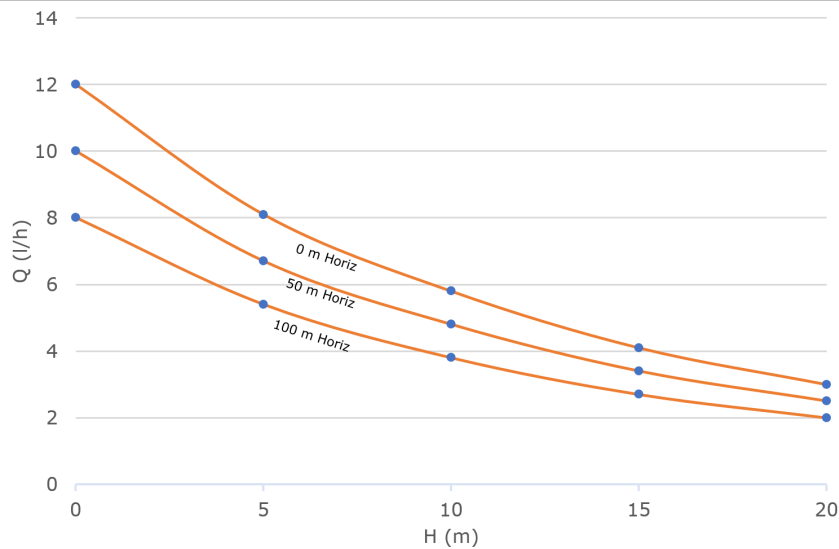

### PSC Condensate Pump for units with humidifier

This pump is used to boost condensate that may have formed on the cooling coil and is collected in the condensate tray. It is also used in units featuring a dehumidifier to manage the water exhausted by this device. Recommended in all cases where the hydraulic connections are carried out exclusively from the top.

All sizes Main specifications

- Length: 221 mm
- Width: 100 mm
- Height: 106 mm
- Power supply: 230 V - 1 ph - 50/60 Hz
- Max. absorption: 75 W

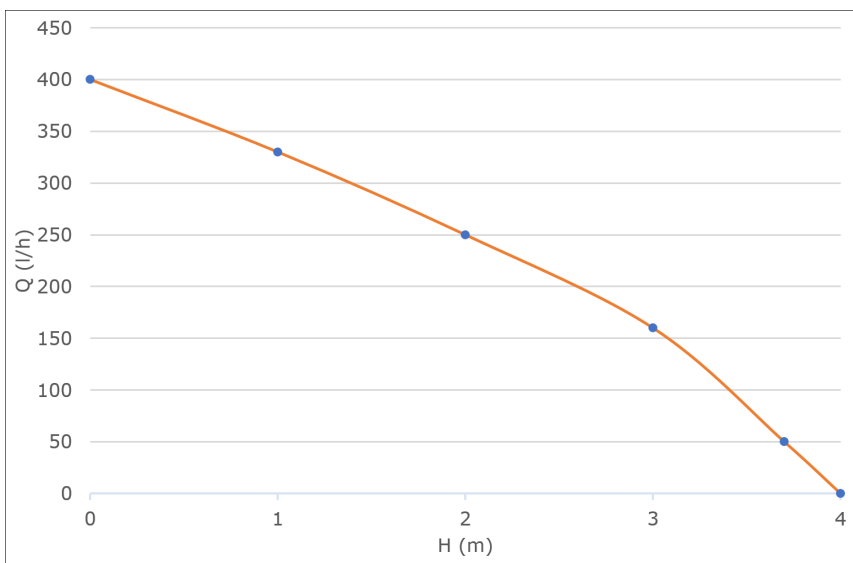

### VRM3 3-way chilled water valve

In chilled water units, this allows control of the supply temperature.

Chilled water valves are brass body, ball valves with equal percentage flow on the straight line and linear flow on the bypass line, including threaded female connectors. These valves are supplied with a modulating, micro-processor-controlled servo onboard the machine with 0-10V signal.

#### SPECIFICATIONS

Model	Kvs (straight line)	Kvs (Bypass line)	max. differential pressure [kPa]
16	6.3	4.0	240
27	10	6.3	240
22	6.3	4.0	240

### VRM2 2-way chilled water valve

In chilled water units, this allows control of the supply temperature in variable water flow rate applications.

The 2-way solution is obtained by closing the bypass line. The technical specifications are the same as the 3-way solution.

### COID Upward hydraulic connections

For chilled water units, these allow the configuration of the units to be adapted to the requirements of the system.

If the layout of the site requires so, dual-circuit units can be supplied with hydraulic connections facing upwards and one circuit on the left and the other on the right.

### CAB Automatic switching between circuits (DW units)

This option provides for automatic switching, which is an extra mode to manage the two circuits in addition to those illustrated above. If the conditions of the primary circuit are no longer suitable for correct unit operation (in terms of water supply and/or temperature), the controller automatically switches to the second circuit.

If the unit features 3-way valves, the controller uses the mechanical flow switch and the input water temperature probe to evaluate whether the circuit is suitable for operation. If the unit features 2-way valves, the virtual flow switch solution is adopted.

The flow switch solution is designed to check the flow even in cases where a physical flow switch is not fitted. The unit periodically opens the valve in the primary circuit (based on a settable time) and indirectly checks whether there is water flowing in the circuit (by calculating the T delta in the coil). If the T delta is zero (no water flow in the circuit), the controller repeats the operation after the selected time.

### UMEI Immersed electrode humidifier

With the option, the unit can be equipped with an immersed electrode humidifier that humidifies the air in cases where the air is extremely dry, if compared to the setpoint stored.

The operating principle of the humidifier is as follows. A container featuring electrodes is filled with water until the electrodes are slightly covered, as water serves as the conducting medium between the electrodes. The Joule effect causes the running current to heat the water which evaporates as soon as it reaches the boiling point.

The output vapour is transferred to the environment. The solution with immersed electrodes is fully safe from a health standpoint and it is designed for proportional adjustment of vapour generation.





There are precise relationships between the humidifier potential and the absorbed power. Generally speaking, the following may be stated:

$$P = 0.75 \times Pv$$

where

P[kW] this is the absorbed power, expressed in kW;

Pv[kg/h] this is the generated vapour, expressed in kg/h.

Moreover:

$$I = \frac{P}{S \times \sqrt{n}}$$

where

I[A] this is the absorbed current, expressed in A;

P[W] this is the absorbed power, expressed in W;

S[V] this is the rated voltage, expressed in V.

n this is the number of phases in the power supply.

This shows a directly proportional relation between the absorbed current and the generated vapour, which may be summarised in the formula below:

$$Pv = \frac{\sqrt{n} \times S}{0.75} \times I$$

where

Pv[kg/h] this is the generated vapour, expressed in kg/h.

n this is the number of phases in the power supply.

S[V] this is the rated voltage, expressed in V.

I[A] this is the absorbed current, expressed in A.

The microprocessor controller proportionally adjusts the output steam, based on the humidification level required in the room, through the regulation of the current absorbed by the electrodes. Additionally, it controls all the operating phases: water filling and discharge, periodic emptying cycle, viewing of operating status and alarm messages. The end user will be able to select whether the control needs to be based on either relative or absolute humidity.

Upon request, the piloting of an external humidifier equipped with its own controller may be implemented with both a 0-10V signal and an On/Off signal.

The table below shows the specifications of the humidifiers fitted on the units.

The humidifier cylinder is not designed for inspections and maintenance. A check should be made that the conditions of feed water to the humidifier are within the allowed limits. Consult the relevant installation, operation and maintenance manual for this purpose. Cylinders designed for inspection can be supplied upon request or cylinders for conductivity ranges other than standard.

<b>Cabinet type</b>		Coolblade
<b>Max. steam output</b>	kg/h	3
<b>Max. absorbed power</b>	kW	2.25
<b>Power supply</b>	V/ph/Hz	230/1/50
<b>Water volume</b>	l	2.5
<b>Max. load capacity</b>	l/min	4 c.a.
<b>Max. load capacity</b>	l/min	0.6
<b>Feed water conductivity</b>	µS/cm	350-1250
<b>Filling fitting,</b>		¾"G, male
<b>Drain fitting</b>	mm	32

## REFRIGERANT CIRCUIT ACCESSORIES

### VTE Electronic expansion valve

For direct expansion units, this is necessary when the condensing unit is not provided with a throttling device. Guarantees constant and precise control of superheating of the sucked-in gas. If available on the condensing unit, a potential-free contact that shows the operating status of the compressor can also be connected to the direct expansion units, thereby optimizing the operation of the electronic expansion valve.

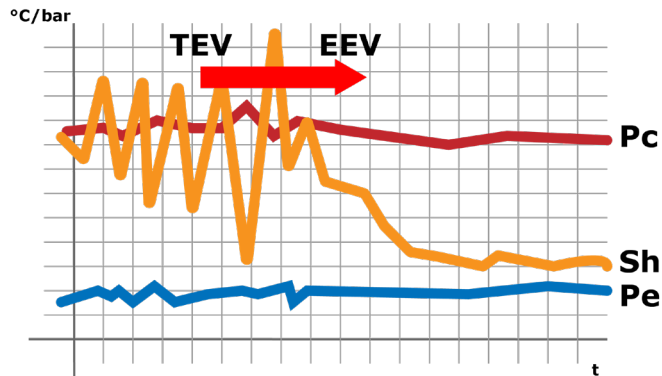

The graph above illustrates the improvement achieved in the controller and in the superheating value (Sh), in parallel with the performance of the evaporation (Pe) and condensing (Pc) pressures, in cases where an electronic valve (E2V) is used.

### LAK Low external temperature kit (-25°C) (Coolblade ED+)

The low external temperature kit is a solution for condensation control in direct expansion units featuring a remote condenser when the external air temperatures are cooler than the min. operational level. It is normally recommended when the engagement of the condenser fans alone is not sufficient.

The system operates according to the condenser flooding principle and condensing pressure regulation is achieved using a mechanical valve (see figure):

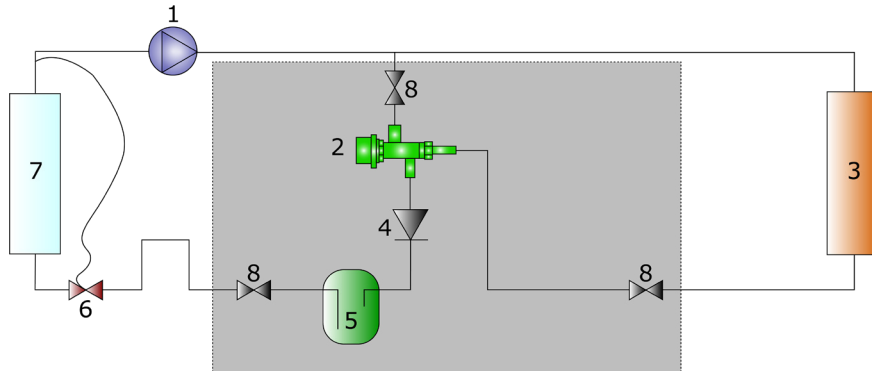

1. Compressor
2. Condensation control valve
3. Condenser
4. Non-return valve
5. Liquid receiver
6. Electronic expansion valve
7. Evaporator
8. Shut-off valve

The kit (two kits for dual circuit units) is supplied as a separate assembly (area within broken line in figure) and it needs to be connected to the unit and to the remote condenser for optimised adaptation to as many unit installations and configurations possible. The kit may be installed near the unit, including underneath a raised floor (where provided), in an indoor place with temperatures exceeding 0°C.

The liquid receiver is not fitted onboard the unit: it will be oversized and installed in the kit.

The option is sized for a min. external air temperature of -25°C.

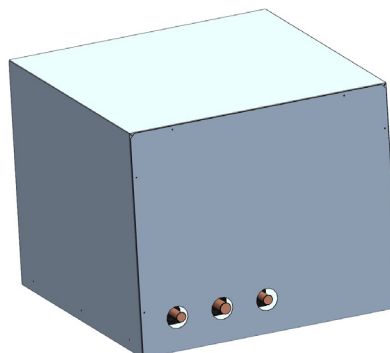
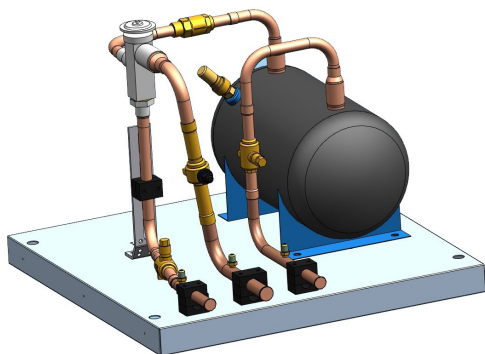

The table below shows information on the max. overall dimensions of each single kit and the increased volume provided by the liquid receiver in each circuit (difference between standard receiver onboard the machine, which is removed, and oversized receiver included in the kit).

Size	Indicative dimensions [mm]	Receiver volume difference [l]	Quantity
13 - 21	602 x 600 x H=500	1.2	1

#### **LAM Low external temperature kit (-35°C) (Coolblade ED+)**

Same construction logic and functionality as LAK. The option is sized for a min. external air temperature of -35°C.

The table below shows information on the max. overall dimensions of each single kit and the increased volume provided by the liquid receiver in each circuit (difference between standard receiver onboard the machine, which is removed, and oversized receiver included in the kit).

Size	Indicative dimensions [mm]	Receiver volume difference [l]	Quantity
13 - 21	602 x 600 x H=500	6.6	1

#### **KT Kit flexible pipes**

The accessory is made off couple of flexible pipes designed to work with the high pressure needed by R410A refrigerant. Pipes are shipped separately, and they allow to make extremely flexible the connection between unit and the plant. This allows to partial move the unit in order to increase the accessibility in case of extraordinary maintenance.

#### **SITL Settings for applications with long pipes (Coolblade ED+)**

This option is required for applications in which the equivalent length between the internal unit and the remote condenser exceeds predefined distances. The option requires proper settings in order to provide for oil return and correct unit operation in similar contexts. Specifically Coolblade ED+ 13 requires it once pipings are within 30 and 60 meters, Coolblade ED+ 21 once pipings are within 50 and 100m.

---

## AERAULIC CIRCUIT OPTIONS

### FG6 Higher efficiency filters (ISO Coarse 75% - G4)

For those applications which need an higher filtration grade, higher efficiency filters are available. Coolblade can therefore be made available with ISO Coarse 75% (according to ISO 16890 - corresponding to EU4 Eurovent BSEN - 779-4/5 - MERV8 with reference to ASHRAE 52.2 - 75% by ASHRAE 52.1). This accessory can be available only with radial fans.

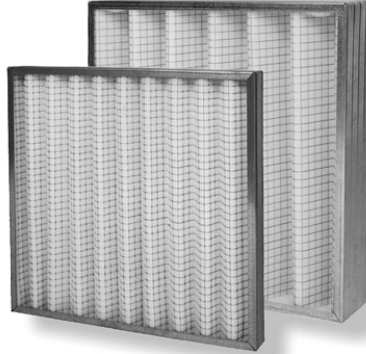

### MF Frontal air delivery with radial fans

The accessory allows to have frontal air delivery even with radial fans. This can be used for those applications which need radial fans' available pressure (for example higher filtration requirements), as well as frontal air distribution.

### CPR Remote pressure delta control

This option is used to check the radial fan speed required to keep the differential air pressure setpoint constant. Units are supplied with a differential sensor with two pressure outlets to be fitted remotely. The sensor is used to check values around zero, i.e. with pressures that switch from negative to positive and vice versa. This is the ideal solution to contain the cold or hot aisle and it contributes to the optimisation of the air flows as it balances the unit flow rate with the server-processed flow rate through pressure balancing in the compartmentalised aisle.

If multiple units operate in the same area, the regulation value may be set to the min.-medium-max. pressure value sensed by each individual transducer.

<b>Min ESP</b>	-50 Pa
<b>Max ESP</b>	+50 Pa

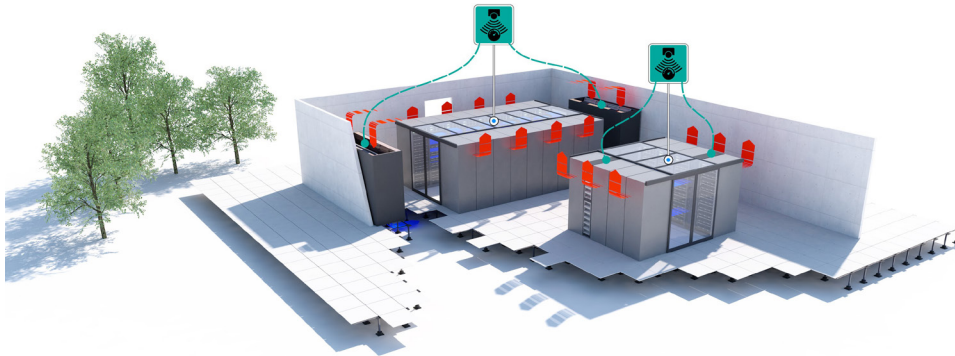

---

## Other accessories

### GCF Filter Covering Grill

The accessory is made off an aesthetic grill placed on the back to cover the filters.

---

## ELECTRICAL ACCESSORIES

### **DAA Dual power supply with automatic switchover**

This allows immediate automatic switching to the other source if one of the two power supplies fails, in order to maintain continuity of service in installations where high redundancy is required. This obligatorily requires a dual power supply system.

As the two sources do not switch instantly, the unit will be switched off, first, and then switched on automatically. If controller switch-off is to be avoided, thus reducing the subsequent switch-on times, a capacitive condenser (BORU) is available as option to keep the controller operational during the switching phase.

This solution necessarily requires that the power cables be supplied with a neutral.

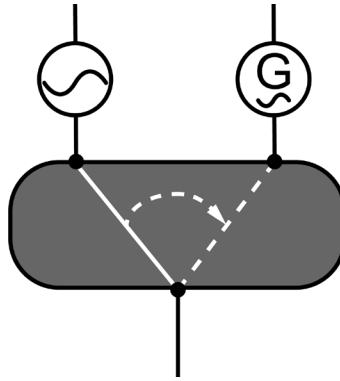

### **BORU Blackout restart**

For quicker restart after a power failure (blackout), the unit can be supplied with capacitive electrical condensers to keep the controller operational for 15 - 20 seconds (depending on its use). This allows for quicker cooling system restart as soon as the power supply is restored (or switches to the other line in cases with dual power supply).

### **FUMO Smoke sensor**

For smoke detection with sensors placed on the unit or in its vicinity This optical sensor is approved at national level by the Ministry of the Interior and it is type-approved at international level in conformity with harmonized European regulations CEN EN 54 part 7 and 8. It can protect an area of 81 sq.m (9x9).

The sensor is supplied bulk for installation on site. As it operates correctly with air speeds below 0.2 m/s, it must be installed outside the unit (not inside it).



The picture on the left shows a fire sensor (FUOCO - FIRE), whereas the picture on the right shows a smoke sensor (FUMO - SMOKE).

### **FUOC Fire sensor**

For fire detection with sensors placed on the unit or in its vicinity The sensor is a thermo-differential sensor and can perceive the speed with which the temperature is rising so as to react quickly to the currents of hot air from a fire. It can protect an area of 49 sq.m (7x7).

The sensor is supplied bulk for installation on site. As it operates correctly with air speeds below 0.2 m/s, it must be installed outside the unit (not inside it).

### **REFF Relais Smoke and/or Fire**

If an external fire/smoke detection system needs to be connected to the units, a 24V relay may be required for connection of the potential-free alarm contact from the field to the microprocessor in the unit.

---

**ALMA No water flow alarm**

For chilled water units (CW), this alarm is used to monitor the input water flow and to warn about flow missing in the form of a message reporting an alarm condition.

The flow meter is supplied bulk for installation by the customer.

This option is not compatible with the 2-way configuration.

**ALMT No voltage alarm**

The No Voltage alarm is a potential-free contact in the terminal board in the electrical control panel. It is closed when the unit is energised.

**A216 Power supply 230 V - 1 ph - 60 Hz**

60Hz power supply for single-phase sizes in the range.

**A46N Power supply 380-400 V - 3 ph - 60 Hz + N**

380-400 V / 60 Hz power supply for three-phase sizes in the range which require a neutral.

The neutral is applied when the internal unit is required to power a single-phase component (remote condenser, remote single-phase dry cooler, condensate exhaust pump) or whenever dual power supply with automatic switching is needed.

**CP Single potential free operating contacts**

All standard units offer the opportunity to remote the signals/functions below through potential-free contacts:

- remote switch-on/off.
- serious alarm;
- Minor alarm (message).

If the configuration is supplemented with the CP option, potential-free contacts are made available in addition to those listed above for the following purposes:

- fan status;
- compressor status (where fitted);

**REL Electrical heaters**

This option is designed to equip the unit with electrical heaters that are used to control heating and/or post-heating.

The heating elements are made of AISI304 steel and have low surface temperature, spiral AISI304 steel fins featuring a safety bimetal thermostat. Elements are grouped in banks made of galvanized sheet metal with a locked electric box.

**SUM Probe for humidity indication**

This probe is available for cool only or cool and heat units and it is used to view the return humidity and the de-humidification value.



## CRM Provision for Remote Condenser with Fan Speed Regulator (Coolblade ED+)

This option is mandatory if an air-condensed, direct expansion unit (EDA) is combined with a remote condenser supplied by our company, type Standard, Plus, Low Noise, with AC fans. This set-up consists in an automatic switch and in the regulation of the fan speed in the remote condenser. Speed is regulated by a phase-cutting speed regulator that is directly commanded by the microprocessor fitted on board the unit. These components are always installed inside the unit.

At installation level, a power connection (phase and neutral) must be created for each cooling circuit between the internal unit and the remote condensers.

In dual circuit units, the unit is supplied with two independent speed regulators to pilot two separate remote condensers.

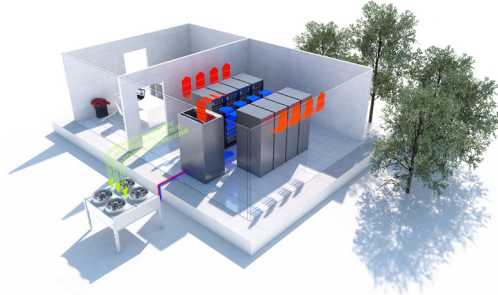

With this solution the remote condenser is an integral part of the internal unit controller, which results in the creation of a system. This brings about a number of benefits. The main ones are listed below:

- **#B#prevention instead of reaction** - with a remote controller, the condenser responds independently to any changes in the local condensing pressure, whereas with the system-oriented approach the internal unit constantly pilots the condenser, based on the application requirements;
- **homogeneous control** - no risk of conflicts between the remote condenser controller and the controller in the internal unit;
- **simplified site operation** - no risk of catastrophic repercussions on internal unit operation as a result of human errors linked to work performed on the remote control;
- **advanced software solutions** - speed-up solutions to ensure operation in extreme conditions such as in the event of cold start-ups with the risk of frost on the fan;

optimization of the system global efficiency thanks to tracking of the best condensation condition;

"Night Shift System" - possibility to set speed limits according to time bands in order to adapt to specific noise conditions on site (e.g. low noise level at night);

- **best response, including in unexpected extreme cases** - design errors (longer piping than expected, narrower piping than required, too close distance between condensers) or poor maintenance (condensers fouled) may cause fake high pressure alarms in remote control conditions. The condenser may "sense" condensing pressures within the limits even in cases when the compressor delivery pressure may have exceeded the limits. Provided that the system design and maintenance must always comply with the guidelines illustrated in the instruction manual for operation, pressure control at machine level directly allows a quicker and more accurate response, including in the extreme cases above.

The table below shows the possible combinations between the fan speed regulators in the remote condenser and the various unit models.

Size	Rated current [A]	Number
13	12	1
21	12	1

## CRHT Provision for Remote Condenser High Temperature (Coolblade ED+)

This option is mandatory if the unit is combined with an HT type remote condenser (high external temperature) supplied by our company. This set-up consists in an automatic switch and in the regulation of the fan speed in the remote condenser. These components are always installed inside the unit.

This solution is equal to the CRM option, the only difference being the size of the speed regulators.

The table below shows the possible combinations of the regulators with the various models.

A speed regulator cannot be installed onboard larger condensers due to space constraints. The speed regulator in these cases will be installed on the remote condenser.

Size	Rated current [A]	Number
13	12	1
21	12	1



### **CREC Provision for Remote EC Condenser (Coolblade ED+)**

This option is mandatory if the unit is combined with an EC type remote condenser supplied by our company. This set-up consists in an automatic switch and in the regulation of the fan speed in the remote condenser. Speed regulation is directly implemented via a modulating signal (0-10V) coming from the internal unit controller. These components are always installed inside the unit.

The operating logic, the system benefits and the currents in the automatic switches are the same as the CRM option.

### **SAL-SA1 Single-point flood sensor**

The flood detection sensor is the recommended solution to monitor possible water leaks which are not visible to the naked eye, typically underneath raised floors. The single-point flood sensor (SAL) consists in a single-point sensor wired to the electrical control panel, which is provided with a long enough cable to position the sensor close to the unit.

The microprocessor warns about the relevant alarm and either switches off the unit or not, based on the selected alarm configuration (serious alarm or simple message).

### **SA2 2 x Single-point flood sensor**

SA2 consists of two single-point sensors: one sensor is wired to the control panel, the other is supplied bulk for installation on site at the required point.

### **SA3 3 x Single-point flood sensor**

SA3 consists of three single-point sensors: one sensor is wired to the control panel, the other two are supplied bulk for installation on site at the required point.

### **SAN Tape extension flood sensor**

The tape extension flood sensor (SAN) consists of a 25m long tape extension sensor. This solution provides for coverage of a larger area around the unit.



The picture shows both the single-point flood sensor (SAL) and the tape extension sensor (SAN).

### **MUSR Multi sensor (4) on return line**

Solution with 4 sensors detecting the return temperatures and calculating the average for multi-point reading of the temperature and for more accurate temperature regulation. The option is supplied separately from the unit and it must be wired on site, based on the specific length requirements of the application layout.

The option connection cable to the unit is 5m long and the cable of each sensor is 6m long.

### **MUSM Multi sensor (4) on delivery line**

Solution with 4 sensors detecting the delivery temperatures and calculating the average for multi-point reading of the temperature and for more accurate temperature regulation. The option is supplied separately from the unit and it must be wired on site, based on the specific length requirements of the application layout.

The option connection cable to the unit is 5m long and the cable of each sensor is 6m long.

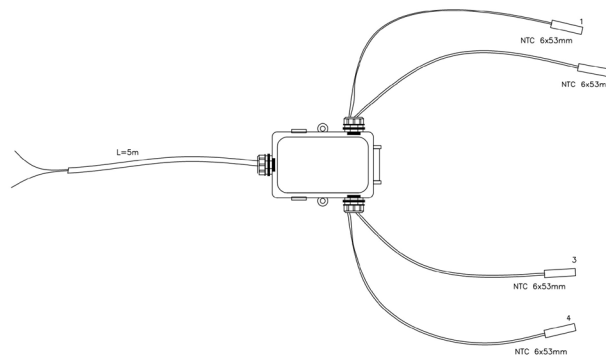



---

**TR1 1 x Remote temperature sensor**

This option is used to command temperature regulation and ventilation based on the values measured by a sensor that is installed in a remote position from the unit (at a max. distance of 30m) and in a closer position to the equipment that requires conditioning.

Where multiple units are fitted, each unit can be supplied with one sensor and the operator can choose whether to use the min., medium or max. value as the reference value.

**TR2 2 x Remote temperature sensor**

This option is used to command temperature regulation and ventilation with the help of two sensors installed in remote positions from the unit (each at a max. distance of 30m). The setpoint of the reference value can be the min., medium or max. value of both sensors.

Where multiple units are installed, the value (min., medium, max.) can be calculated as an average of the measurements by all featured sensors.

This option is also designed for use of the T Delta controller. This controller solution is conceived to balance the air flow rate processed by the conditioners with the air flow rate processed by the servers in the most accurate and continuous way possible.

The controller can pilot machine ventilation in such way that the difference (delta) between the unit input and output temperature is equal to the difference processed by the servers. For instance. If the application has either hot or cold aisle containment, the regulation of the cold source (compressor / valve) can be set to keep the delivery temperature constant and the fan regulation can be set so that the T delta between the input and output temperature (and the air flow rate as a result) is equal to the delta measured between the front and the back of the servers (including their flow rate).

The efficiency of this solution is enhanced with multiple units. When multiple units are fitted, a higher number of remote readings will be available and their min., medium and max. values can be processed.

The controller changes the fan speed iteratively, according to a logic by which the speed is either increased or reduced until the controller senses the correct air flow. For instance. When the delta temperature processed by the units is greater than the remote reference delta temperature, the controller will increase the fan speed through a small incremental step. The opposite will apply if the delta temperature measured in the machine is smaller than the remote reference delta.

The control is thus extremely regular and precise and brisk actions on the ventilation system are prevented, which may eventually disturb the conditions in front of the servers.

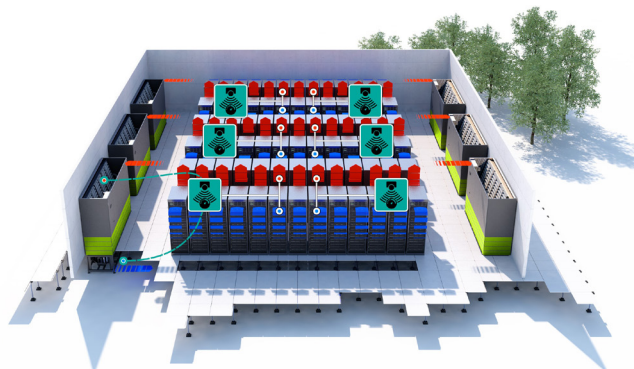
**TR3 3 x Remote temperature sensor**

This option is used to command temperature regulation and ventilation with the help of three sensors installed in remote positions from the unit (each at a max. distance of 30m). The setpoint of the reference value can be the min., medium or max. value of both sensors.

Where multiple units are installed, the value (min., medium, max.) can be calculated as an average of the measurements by all featured sensors.

**TUR1 1 x Remote temperature and humidity sensor**

This option is used to command temperature regulation and ventilation and to regulate humidity (either relative or absolute) with the help of a sensor installed in a remote position from the unit (at a max. distance of 30m). in a closer position to the equipment that requires conditioning.

Where multiple units are fitted, each unit can be supplied with one sensor and the operator can choose whether to use the min., medium or max. value as the reference value.

**TUR2 2 x Remote temperature and humidity sensor**

This solution is under all aspects equivalent to the solution with two sensors for remote temperature detection only (each at a max. distance of 30m from the unit). The only significant difference is that the remote sensors in this case can be used to also manage the control of the overall humidity in the room.

**TUR3 3 x Remote temperature and humidity sensor**

This option is used to command temperature regulation and ventilation, and to regulate humidity (either relative or absolute), with the help of three sensors installed in remote positions from the unit (at a max. distance of 30m). The setpoint of the reference value can be the min., medium or max. value of both sensors.

Where multiple units are installed, the value (min., medium, max.) can be calculated as an average of the measurements by all featured sensors.

## CWDS Chilled water dynamic setpoint

A chilled water system consists of two separate sub-systems: internal units and external chillers (possibly, free cooling type). At partial loads and with a constant flow rate to the primary circuit (or a variable flow rate below the min. flow rate thresholds), the chiller system outputs water at the standard setpoint and this water is then partially recirculated either inside the unit (3-way valves) or through the flow separation system (tank, piping, etc.). This reflects into a system energy inefficiency.

As the highest amount of energy is consumed by the chiller unit, in the ideal operating condition the chiller setpoint should be modified dynamically so as to deliver water to the air conditioners at the highest temperature possible, compatibly with the thermal load. This exponentially improves the system efficiency: as the water temperatures are increased, evaporation improves (in direct expansion mode) and the hours of free cooling increase remarkably.

Solutions have been developed over time to increase the water setpoint of the external chiller unit in an inversely proportional manner, for instance, through a 0-10V proportional signal upon an internal load request. This type of solutions only partly responds to the needs of modern Data Centres. The 0-10V only is a strong limitation in terms of point to point connection of each individual machine (when the connection is lost, the signal is lost too). Additionally, it does not efficiently provide for temperature control on the air delivery line (a far more critical factor as it directly impacts the temperature in front of the servers).

With the CWDS option, direct and smart communication is guaranteed between the set of internal machines and the external chillers, which are supplied by Swegon-Blue Box. Communication is not implemented through one single analog signal, but via continuous exchange of information at a higher level.

This is how internal units dynamically change the water setpoint of the connected chillers, based on the cold water valve position. More specifically, the more the valve is closed, the more the water temperature setpoint is increased; on the other hand, if the valve tends to its max. opening, the internal units will require the chillers to reduce their water setpoint. This prevents sudden disturbance to negatively affect the temperature/pressure in the room.

The aim of the logic is to stabilise the water temperature to such condition that the valve opens in the area where its energy consumption is optimised, leaving a margin for reaction under sudden peak loads, if any.

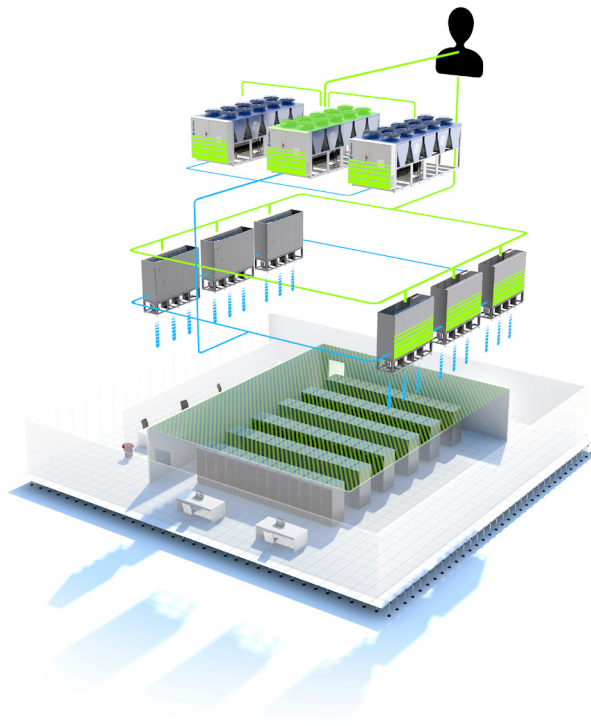

---

The picture above shows an example of a typical system featuring a set of internal units and a set of external free cooling chillers.

The solution with smart communication between internal and external units, however, offers the opportunity to provide for solutions with one-to-one systems. This solution requires that each single unit be connected to one single external free cooling chiller. Although it may appear to be less cost-effective, this solution actually is, if the concept of redundancy is added to the equation.

Example.

- Traditional design: 500 kW load handled using 5+1 internal units, 100 kW each, and 2+1 external free cooling, multi scroll chillers, 250 kW each; uncoupled primary and secondary pumping systems.
- One-to-one design: 500 kW load handled using 5+1 internal units, each connected to a free cooling, scroll inverter chiller, 100 kW; direct pumping system between chiller and internal unit, with inertia tank directly installed onboard the chiller.

The economic result generated by the chiller section only (as determined by comparing the investment in the chillers only, excluding pipes, tanks and pumping systems) gives a **saving of 15% in one-to-one design**. The above applies even if the units included in the second solution offer an additional inverter on the compressors. The reason for this is redundancy. In a one-to-one system the exceeding cooling capacity can be reduced to cover the N+1 demand, which is the very reason for the above-mentioned saving.

Moreover, a saving is also obtained at system level because of the reduced number of tanks and pumping units.

This solution, however, only works if the system can be converted into a "system of systems". In this case, the CWDS option offers a set of solutions specifically conceived for this application.

- The internal units pilot the demand from the chillers according to the load (when an internal unit is switched on, the chiller is pre-activated to pre-cool the water in the circuit and to provide for greater temperature stability).
- If a unit or the chiller connected to such unit is alarmed, all units in standby start their dedicated chiller in quick start-up mode for better service continuity.
- Units in standby, if any, in systems featuring free cooling chillers are started up to increase the free cooling capacity, when the external conditions allow so.
- Every internal unit - free cooling chiller system will dynamically optimise the water temperature for maximised free cooling of each individual sub-system as well.

These advanced logics, including from the standpoint of energy savings, enable the one-to-one system of the previous example to obtain **an annual saving of 21%, as calculated taking the climate profile in Frankfurt as reference**, over the total energy consumed by the chillers and the pumping system in one year.

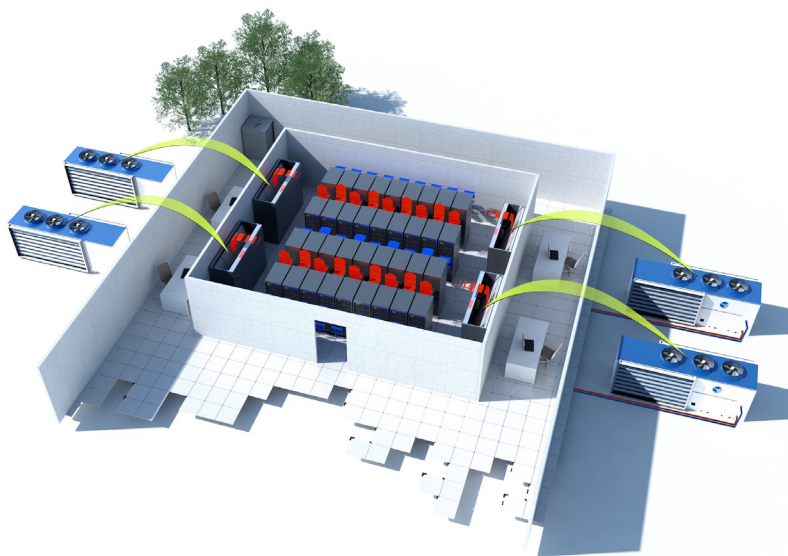

The one-to-one solution also offers an additional series of interesting advantages:

- the modularity and scalability of a direct expansion system combined with the effectiveness of a chilled water system with optimised free cooling;
- the possibility to implement a variable flow rate on the chiller in a simple and linear manner without the complications implied in a multi-machine system;
- a simplified layout and a very strong reduction of costs with TIER 3 or TIER 4 design.

---

## NETWORK ACCESSORIES

### BAC BacNet serial board

Serial connection boards allow connection to supervision and remote management systems, thereby making it possible to display the main operating parameters and edit the main operational parameters. The BacNet serial board allows connection to supervision systems with the MS/TP protocol.

The monitoring solution is BTL-certified (BACnet Testing Laboratories) and ensures that the system is developed and tested according to the highest standards in the industry.



### PBA BACnet protocol over IP (Ethernet)

The controller is set for use, in read and write mode, of the BACnet port on IP protocol.

By default, the programming gives read-only access to the control of the unit. Enabling of read/write access should be requested when ordering.

The monitoring solution is BTL-certified (BACnet Testing Laboratories) and ensures that the system is developed and tested according to the highest standards in the industry.



### PSN SNMP protocol

The accessory consists of a gateway that allows Ethernet connection to a SNMP manager supervision system.



### GLO Modbus Lonworks Gateway

With this accessory, a RS485/Lon gateway is installed inside the electrical control panel.

By default, the programming gives read-only access to the control of the unit. Enabling of read/write access should be requested when ordering.



### GRLD Datalink local network management

The local network Datalink is managed for communication among the various air conditioning units for the purpose of optimising system operation in terms of control efficiency and effectiveness. The local network Datalink is designed for connection of multiple Datatech BTD units (up to 32).



Management of the local network Datalink converts a set of multiple machines into one single smart system and is designed for the configuration of unit control in the system via different solutions.

- **Running-Standby** This function is intended to control redundant units that rotate together with the main units allowing for their homogeneous use and preventing possible conflicts between machines.

Units in standby can also be called up in the event of serious alarms occurring in the active units.

Finally, a function can be configured to call up units in standby if a Hot Spot is provided in the room.

This configuration is recommended with units having a fixed cold source (e.g. stationary compressors).

To address any localised hot spots, each single machine can be configured to automatically exit the network for a predefined time when peak loads need to be covered. As soon as the emergency condition has been solved, the units are networked again.

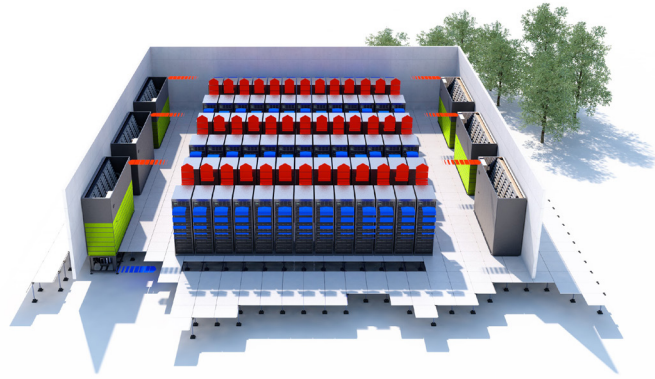

- Distributed control** Units operate as if they were one big machine. Units share the values read by the probes and they operate according to the averages (max. or min. values) of all detected signals. To address any localised hot spots, each single machine can be configured to automatically exit the network for a predefined time when peak loads need to be covered. As soon as the emergency condition has been solved, the units are networked again. This solution is recommended with units having a cold source, a modulating fan and a thermal load close to the nominal value.

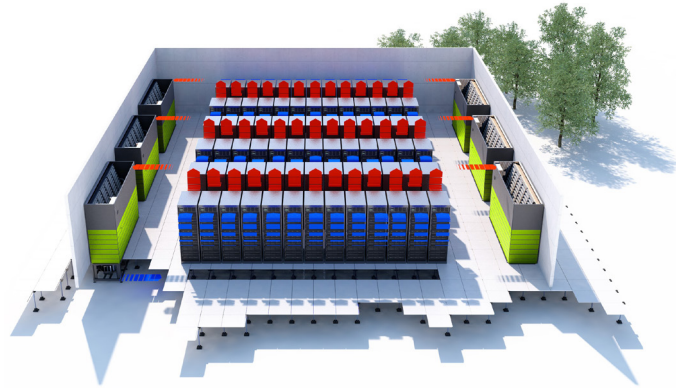

- Dynamic and Continuous Optimisation** This function was developed to help the networked machines follow the load trends over time (both in terms of cold source and ventilation) in the most effective manner possible. Units share the readings of the probes and they are enabled one at a time as the demand grows. In other words, as using the performance of the efficiency curves of components with brushless motors (e.g. EC fans) is the final target, the system does not wait until each unit is saturated before calling the next one; the second unit is indeed enabled as soon as the first one has achieved the threshold which represents the max. efficiency point. Active units operate as if they were one big unit. With this solution, the number of machines always in operation within their max. efficiency area is the minimum required. This solution is recommended with units having a cold source, a modulating fan and a variable thermal load over time.

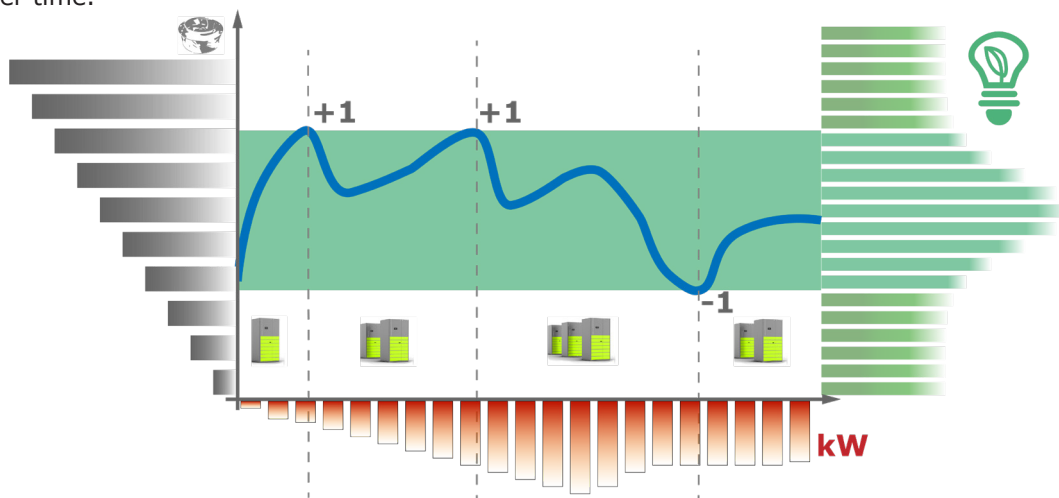

If the connection between the units fails, the units will individually work in "stand alone" mode.



# TECHNICAL SPECIFICATIONS

## Coolblade DX

Unit size			12/12L	19/19L	25/25L
Total refrigeration capacity	(1)	kW	12.5	19.1	24.4
Sensible cooling capacity	(1)	kW	12.5	19.1	24.4
SHR			1.0	1.0	1.0
Total refrigeration capacity	(2)	kW	14.4	21.7	27.9
Sensible cooling capacity	(2)	kW	14.4	21.7	27.9
SHR			1.0	1.0	1.0
Total refrigeration capacity	(3)	kW	11.6	19.3	25.8
Sensible cooling capacity	(3)	kW	11.6	19.3	25.8
SHR			1.00	1.00	1.00
<b>Fans</b>					
Number			3	4	5
Nominal air flow rate		m <sup>3</sup> /h	3,300	4,200	4,900
Min. air flow rate		m <sup>3</sup> /h	2,150	2,730	3,190
<b>Axial version</b>					
Power input with nominal airflow		kW	0.14	0.25	0.41
Max. air flow rate		m <sup>3</sup> /h	4000	4700	4900
<b>Radial version, delivery from both sides</b>					
Power input with nominal airflow			0.38	0.51	0.60
Max. air flow rate		m <sup>3</sup> /h	3500	4500	5400
<b>Radial version, delivery from one side</b>					
Power input with nominal airflow			0.45	0.63	0.79
Max. air flow rate		m <sup>3</sup> /h	3350	4200	4900
<b>Noise levels</b>					
Sound power level on suction side	(4)	dB(A)	71.0	72.3	73.4
Sound power level on supply side	(4)	dB(A)	74.0	75.3	76.4
Sound power level on suction side	(5)	dB(A)	73.9	75.0	76.1
Sound power level on supply side	(5)	dB(A)	78.3	79.5	80.4
<b>Refrigerant circuit</b>					
Suction connection		n°x mm	1x16	1x18	1x18
Liquid connection		n°x mm	1x12	1x12	1x16
<b>Blue Box matching condensing unit</b>					
Model			Epsilon Echos+LE 15	Epsilon Echos+LE 20	Epsilon Echos+LE 26
Compressor power input	(1)	kW	3.2	4.3	5.6
Compressor power input	(2)	kW	5.2	6.8	8.6
Fan power input		kW	0.3	0.8	1.3
<b>Dimensions and weights of basic unit</b>					
Length		mm	300	300	300
Depth		mm	1,000	1,000	1,000
Height	(6)	mm	2,003	2,003	2,003
Operating weight		kg	120	130	140
<b>Dimensions and weight of "L" units</b>					
Length		mm	300	300	300
Depth		mm	1,200	1,200	1,200
Height	(6)	mm	2,003	2,003	2,003
Operating weight		kg	160	170	180

All performance data are given at the following conditions: incoming air 35°C/27%RH

- (1) Compressor speed 90rps, ambient air 35°C
- (2) Compressor speed 120rps, ambient air 35°C
- (3) Saturated evaporating temperature 12°C, saturated condensing temperature 45°C
- (4) Axial fans, maximum air flow
- (5) Radial fans, maximum airflow
- (6) Height can be adjusted between 2003 and 2025mm

## Coolblade ED+

Unit size			13/13L	21/21L
Total refrigeration capacity	(1)	kW	13.1	19.8
Sensible cooling capacity	(1)	kW	13.1	19.8
Compressor power input	(1)	kW	3.0	4.3
SHR	(1)		1.0	1.0
Total refrigeration capacity	(2)	kW	15.8	23.2
Sensible cooling capacity	(2)	kW	15.8	23.2
Compressor power input	(2)	kW	4.8	6.2
SHR	(2)		1.0	1.0
Total refrigeration capacity	(3)	kW	16.9	24.7
Sensible cooling capacity	(3)	kW	16.9	24.7
Compressor power input	(3)	kW	4.8	6.0
SHR	(3)		1.00	1.00
<b>Fans</b>				
Number			4	5
Nominal air flow rate		m <sup>3</sup> /h	4,000	4,000
Min. air flow rate		m <sup>3</sup> /h	2,800	2,800
<b>Axial version</b>				
Power input with nominal airflow		kW	0.258	0.405
Max. air flow rate		m <sup>3</sup> /h	4,4000	4,000
<b>Radial version, delivery from both sides</b>				
Power input with nominal airflow			0,624	0,791
Max. air flow rate		m <sup>3</sup> /h	4,550	5,400
<b>Radial version, delivery from one side</b>				
Power input with nominal airflow			0,624	0,791
Max. air flow rate		m <sup>3</sup> /h	4,550	5,400
<b>Noise levels</b>				
Sound power level on suction side	(4)	dB(A)	73.1	73.4
Sound power level on supply side	(4)	dB(A)	76.3	76.6
Sound power level on suction side	(5)	dB(A)	76.7	77.0
Sound power level on supply side	(5)	dB(A)	80.0	80.3
<b>Refrigerant circuit</b>				
Suction connection		n°x mm	1x12	1x16
Liquid connection		n°x mm	1x12	1x12
<b>Blue Box matching condensing unit</b>				
Standard Model (AC/EC Fan/s)			NHNM 1145.3	NHNM 1245.2
Standard Model LN (AC/EC Fan/s)			NHLM 1150.4	NHLM 1245.3
Oversized Model (AC/EC Fan/s)			NHNM 1245.2	NHNM 1245.4
Oversized Model LN (AC/EC Fan/s)			NHLM 1245.3	NHLM 2245.2
HT Model (AC Fan/s)			NHNM 1245.4	NHNM 2245.2
<b>Dimensions and weights of basic unit</b>				
Length		mm	300	300
Depth		mm	1,000	1,000
Height	(6)	mm	2,003	2,003
Operating weight		kg	120	130
<b>Dimensions and weight of "L" units</b>				
Length		mm	300	300
Depth		mm	1,200	1,200
Height	(6)	mm	2,003	2,003
Operating weight		kg	160	170

All performance data are given at the following conditions: incoming air 35°C/27%RH

- (1) Compressor speed 90 rps, saturated condensing temperature 45°C
- (2) Compressor speed 120 rps, saturated condensing temperature 45°C, Axial Fans
- (3) Compressor speed 120 rps, saturated condensing temperature 45°C, Radial Fans
- (4) Axial fans, maximum air flow
- (5) Radial fans, maximum airflow
- (6) Height can be adjusted between 2003 and 2025mm

## Coolblade CW - DW

Unit size			16/16L	27/27L	36L	22/22L
Total refrigeration capacity	(1)	kW	16.5	27.2	35.4	21.8
Sensible cooling capacity	(1)	kW	16.5	27.2	35.4	21.8
NSEER with axial fans	(1)		125.9	63.8	-	50.9
NSEER with radial fans	(1)		43.6	44.3	16.02	35.3
<b>Fans</b>						
Number			3	5	4	5
Nominal air flow rate		m3/h	3,200	4,800	7,290	4,800
Min. air flow rate		m3/h	2,150	3,190	1,820	3,190
<b>Axial version</b>						
Power input with nominal airflow		kW	0.13	0.42	-	0.42
Max. air flow rate		m3/h	3,400	4,800	-	4,800
<b>Radial version, delivery from both sides</b>						
Power input with nominal airflow			0.37	0.60	2.08	0.60
Max. air flow rate		m3/h	3,600	5,200	7,300	5,200
<b>Radial version, delivery from one side</b>						
Power input with nominal airflow			0.42	0.79	2.08	0.79
Max. air flow rate		m3/h	3,300	4,800	7,300	4,800
<b>HYDRAULIC CIRCUIT</b>						
Number of hydraulic circuits			1	1	1	2
Total pressure drop without valves	(1)	kPa	26	36	45	45
Total pressure drop with valves	(1)	kPa	46	60	81	79
Connectors			G3/4"	G1"	G1"	2xG3/4"
Internal volume		dm <sup>3</sup>	8.5	14.8	16.2	2x8,5
<b>Noise levels</b>						
Sound power level on suction side	(2)	dB(A)	71.1	73.4	-	73.4
Sound power level on supply side	(2)	dB(A)	74.1	76.4	-	76.4
Sound power level on suction side	(3)	dB(A)	73.9	76.1	92.8	76.1
Sound power level on supply side	(3)	dB(A)	78.3	80.4	93.7	80.4
<b>Dimensions and weights of basic unit</b>						
Length		mm	300	300	-	300
Depth		mm	1,000	1,000	-	1,000
Height	(4)	mm	2,003	2,003	-	2,003
Operating weight		kg	118	136	-	143
<b>Dimensions and weight of "L" units</b>						
Length		mm	300	300	300	300
Depth		mm	1,200	1,200	1,200	1,200
Height	(4)	mm	2,003	2,003	2,003	2,003
Operating weight		kg	132	151	162	159

All performance data are given at the following conditions: incoming air 35°C/27%RH

(1) Inlet/outlet water temperature 13/18°C

(2) Axial fans, maximum air flow

(3) Radial fans, maximum airflow

(4) Height can be adjusted between 2003 and 2025mm



# ELECTRICAL DATA

## Coolblade DX

Unit size			12/12L	19/19L	25/25L
Maximum absorbed power for unit only cooling	(1)	kW	0.25	0.33	0.42
Maximum absorbed current for unit only cooling	(1)	A	2.2	2.9	3.6
Maximum absorbed power for unit only cooling	(2)	kW	0.50	0.67	0.84
Maximum absorbed current for unit only cooling	(2)	A	4.2	5.6	7.0
Delta power absorption for electrical heaters		kW	+3.3	+3.3	+3.3
Delta current absorption for electrical heaters		A	+14.3	+14.3	+14.3
Delta power absorption for humidifier		kW	+1.1	+1.1	+1.1
Delta current absorption for humidifier		A	+4.9	+4.9	+4.9
Maximum absorbed power for unit cooling + heating + humidification	(1)	kW	4.65	4.73	4.82
Maximum absorbed current for unit cooling + heating + humidification	(1)	A	21.4	22.1	22.8
Maximum absorbed power for unit cooling + heating + humidification	(2)	kW	4.9	5.07	5.24
Maximum absorbed current for unit cooling + heating + humidification	(2)	A	23.4	24.8	26.2
Power supply		V/ph/Hz	230/1~/50 ±5%	230/1~/50 ±5%	230/1~/50 ±5%

(1) Axial fans

(2) Radial fans

## Coolblade ED+

Unit size			13/13L	21/21L
Maximum absorbed power for unit only cooling	(1)	kW	6.0	10.0
Maximum absorbed current for unit only cooling	(1)	A	16.9	20.1
Maximum absorbed power for unit only cooling	(2)	kW	7.0	11.0
Maximum absorbed current for unit only cooling	(2)	A	19.4	23.5
Delta power absorption for electrical heaters		kW	+3.3	+3.3
Delta current absorption for electrical heaters		A	+14.3	+14.3
Delta power absorption for humidifier		kW	+1.1	+1.1
Delta current absorption for humidifier		A	+4.9	+4.9
Maximum absorbed power for unit cooling + heating + humidification	(1)	kW	10.4	14.4
Maximum absorbed current for unit cooling + heating + humidification	(1)	A	36.1	39.3
Maximum absorbed power for unit cooling + heating + humidification	(2)	kW	11.4	15.4
Maximum absorbed current for unit cooling + heating + humidification	(2)	A	38.6	42.7
Power supply		V/ph/Hz	400/3~/50 ±5% + Neutral	400/3~/50 ±5% + Neutral

(1) Axial fans

(2) Radial fans

## Coolblade CW - DW

Unit size			16/16L	27/27L	36L	22/22L
Max. absorbed power	(1)	kW	0.25	0.42	-	0.42
Max. absorbed current	(1)	A	2.2	3.6	-	3.6
Max. absorbed power	(2)	kW	0.5	0.8	2.2	0.8
Max. absorbed current	(2)	A	4.2	7.0	9.0	7.0
Delta power absorption for electrical heaters		kW	+3.3	+3.3	-	+3.3
Delta current absorption for electrical heaters		A	+14.3	+14.3	-	+14.3
Delta power absorption for humidifier		kW	+1.1	+1.1	-	+1.1
Delta current absorption for humidifier		A	+4.9	+4.9	-	+4.9
Maximum absorbed power for unit cooling + heating + humidification	(1)	kW	4.65	4.82	-	4.82
Maximum absorbed current for unit cooling + heating + humidification	(1)	A	21.4	22.8	-	22.8
Maximum absorbed power for unit cooling + heating + humidification	(2)	kW	4.9	5.2	-	5.2
Maximum absorbed current for unit cooling + heating + humidification	(2)	A	23.4	26.2	-	26.2
Power supply		V/ph/Hz	230/1~/50 ±5%	230/1~/50 ±5%	230/1~/50 ±5%	230/1~/50 ±5%

(1) Axial fans

(2) Radial fans

# NOISE LEVELS

## COOLBLADE DX-CW-DW (Axial Fans)

### Supply side

Model	Sound power level in octave band [dB]								A-weighted sound power level discharge side [dB(A)]
	Central frequency [Hz]								
	63	125	250	500	1000	2000	4000	8000	
Coolblade DX12/12L - CW16/16L	33.1	51.3	65.3	66.8	69.6	69.5	62.3	<b>51.3</b>	<b>74.1</b>
Coolblade DX19/19L	34.3	52.5	66.5	68.0	70.8	70.7	63.5	<b>52.5</b>	<b>75.3</b>
Coolblade DX25/25L - CW27/27L - DW22/22L	35.3	53.5	67.5	70.0	71.8	71.6	64.4	<b>53.5</b>	<b>76.4</b>

### Suction side

Model	Sound power level in octave band [dB]								A-weighted sound power level supply side [dB(A)]
	Central frequency [Hz]								
	63	125	250	500	1000	2000	4000	8000	
Coolblade DX12/12L - CW16/16L	31.7	51.7	67.9	69.4	66.9	63.1	54.9	<b>43.9</b>	<b>71.1</b>
Coolblade DX19/19L	33.0	52.9	69.1	70.6	68.1	64.3	56.1	<b>45.1</b>	<b>72.3</b>
Coolblade DX25/25L - CW27/27L - DW22/22L	33.9	53.9	70.1	71.6	69.1	65.3	57.0	<b>46.0</b>	<b>73.4</b>

## COOLBLADE DX-CW-DW (Radial Fans)

### Supply side

Model	Sound power level in octave band [dB]								A-weighted sound power level discharge side [dB(A)]
	Central frequency [Hz]								
	63	125	250	500	1000	2000	4000	8000	
Coolblade DX12/12L - CW16/16L	36.4	48.4	61.7	73.8	73.5	73.3	65.5	<b>58.8</b>	<b>78.3</b>
Coolblade DX19/19L	37.6	49.6	62.9	75.0	74.7	74.5	66.7	<b>60.0</b>	<b>79.5</b>
Coolblade DX25/25L - CW27/27L - DW22/22L	38.6	50.6	63.9	76.0	75.7	75.4	67.7	<b>61.0</b>	<b>80.4</b>
Coolblade CW36L	74.8	78.8	82.1	90.4	88.7	90.2	85.2	<b>84.3</b>	<b>94.1</b>

### Suction side

Model	Sound power level in octave band [dB]								A-weighted sound power level supply side [dB(A)]
	Central frequency [Hz]								
	63	125	250	500	1000	2000	4000	8000	
Coolblade DX12/12L - CW16/16L	34.0	47.8	61.4	72.4	69.2	66.7	60.1	<b>51.3</b>	<b>73.9</b>
Coolblade DX19/19L	35.2	49.0	62.6	73.6	70.4	67.9	61.3	<b>52.5</b>	<b>75.0</b>
Coolblade DX25/25L - CW27/27L - DW22/22L	36.2	50.0	63.6	74.6	71.4	68.9	62.3	<b>53.5</b>	<b>76.1</b>
Coolblade CW36L	76.4	80.1	82.1	89.2	88.3	89.9	84.2	<b>82.1</b>	<b>93.4</b>

## COOLBLADE ED+ (Axial Fans)

### Supply side

Model	Sound power level in octave band [dB]								A-weighted sound power level discharge side [dB(A)]
	Central frequency [Hz]								
	63	125	250	500	1000	2000	4000	8000	
Coolblade ED+ 13	43.8	48.6	56.0	67.3	72.9	71.5	64.9	<b>53.4</b>	<b>76.3</b>
Coolblade ED+ 21	44.3	49.0	56.4	67.6	73.2	71.8	65.0	<b>53.3</b>	<b>76.6</b>

### Suction side

Model	Sound power level in octave band [dB]								A-weighted sound power level supply side [dB(A)]
	Central frequency [Hz]								
	63	125	250	500	1000	2000	4000	8000	
Coolblade ED+ 13	28.2	49.6	67.7	62.8	67.9	67.3	59.9	<b>47.6</b>	<b>73.1</b>
Coolblade ED+ 21	28.7	50.0	68.1	63.1	68.2	67.6	60.0	<b>47.5</b>	<b>73.4</b>

## COOLBLADE ED+ (Radial Fans)

### Supply side

Model	Sound power level in octave band [dB]								A-weighted sound power level discharge side [dB(A)]
	Central frequency [Hz]								
	63	125	250	500	1000	2000	4000	8000	
Coolblade ED+ 13	46.8	51.8	59.2	70.8	76.4	75.5	68.9	<b>57.5</b>	<b>80.0</b>
Coolblade ED+ 21	47.3	52.2	59.6	71.1	76.7	75.8	69.0	<b>57.4</b>	<b>80.3</b>

### Suction side

Model	Sound power level in octave band [dB]								A-weighted sound power level supply side [dB(A)]
	Central frequency [Hz]								
	63	125	250	500	1000	2000	4000	8000	
Coolblade ED+ 13	31.2	52.8	70.9	66.3	71.4	71.3	63.9	<b>51.7</b>	<b>76.7</b>
Coolblade ED+ 21	31.7	53.2	71.3	66.6	71.7	71.6	64.0	<b>51.6</b>	<b>77.0</b>

# REFRIGERANT DIAGRAMS

## COOLBLADE DX

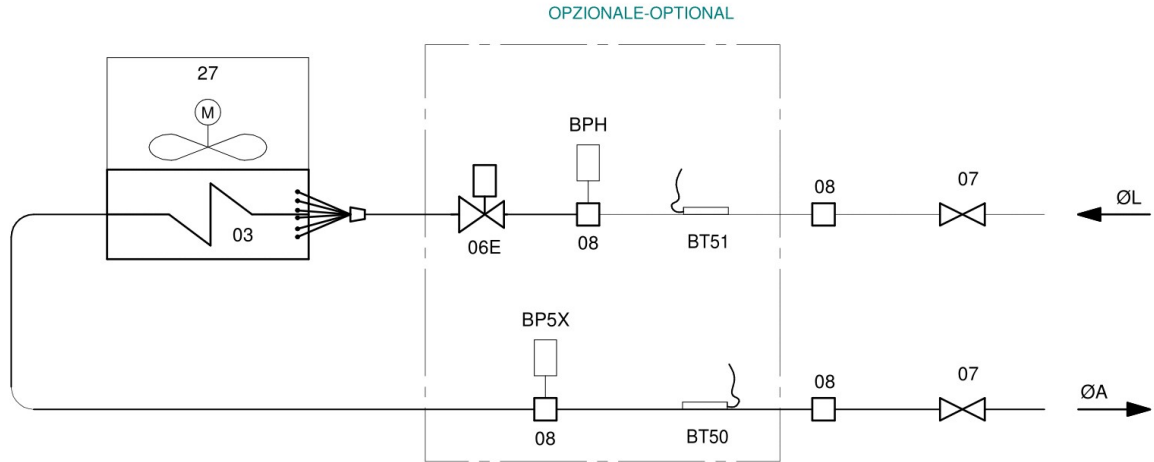

03	Evaporatore	Evaporator
06E	Valvola di Espansione Elettronica	Electronic Expansion Valve
07	Rubinetto Linea del Liquido	Liquid Line Valve
08	Preso di Carica	Charging Connection
27	Ventilatore EC	EC Fan
BPH	Trasduttore di Alta Pressione	High Pressure Transducer
BP5X	Trasduttore di Pressione Valvola Elettronica	Pressure Transducer Electronic Expansion Valve
BT5X	Sonda di Temperatura Valvola Elettronica	Temperature Probe Electronic Expansion Valve

TUBO RAME - COPPER PIPE (Ø mm)			
TAGLIA - SIZE	12	19	25
ØA	Ø16	Ø18	
ØL	Ø12		Ø16

## COOLBLADE ED+

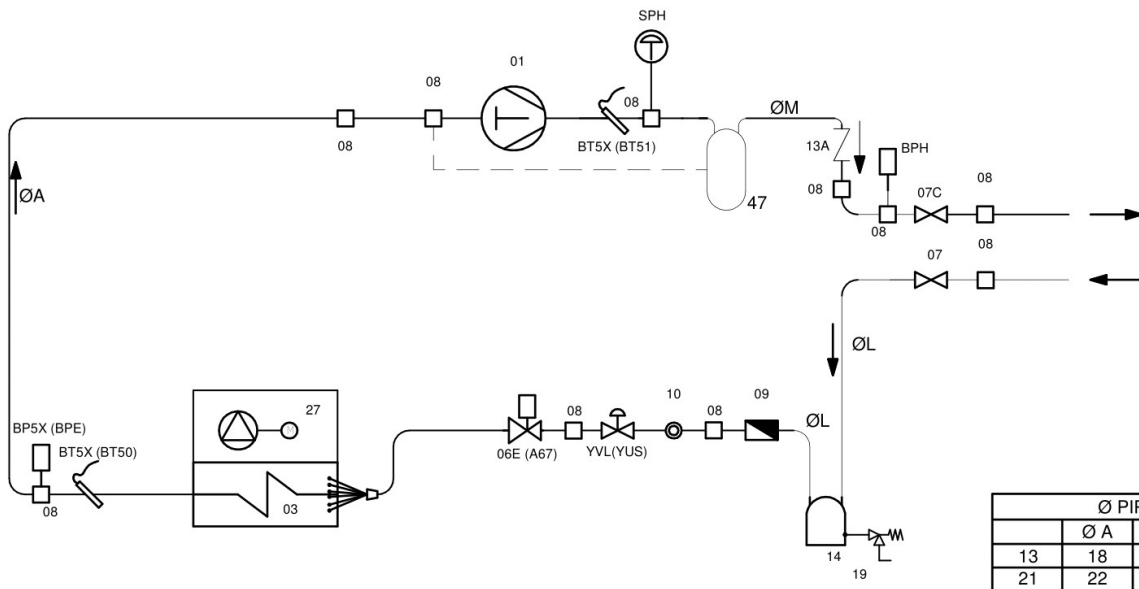

Ø PIPE			
	Ø A	Ø M	Ø L
13	18	12	12
21	22	16	12

01	Compressore	Compressor
03	Evaporatore	Evaporator
06E	Valvola di Espansione Elettronica	Electronic Expansion Valve
07	Rubinetto Linea del Liquido	Liquid Line Valve
07C	Rubinetto Linea di Mandata	Discharge Line Valve
08	Preso di Carica	Charging Connection
09	Filtro Linea Liquido	Liquid Line Filter
10	Indicatore umidità	Moisture Indicator Sight Glass
13A	Valvola di Ritengo Linea di Mandata	Delivery Line Check Valve

14	Ricevitore di Liquido	Liquid Receiver
19	Valvola di Sicurezza	Safety Valve
27	Ventilatore EC	EC Fan
47	Separatore Olio	Oil Separator
BPH	Trasduttore di Alta Pressione	High Pressure Transducer
BP5X	Trasduttore di Pressione Valvola Elettronica	Pressure Transducer Electronic Expansion Valve
BT5X	Sonda di Temperatura Valvola Elettronica	Temperature Probe Electronic Expansion Valve
SPH	Pressostato Alta Pressione	High Pressure Switch
YVL	Valvola Solenoide Linea del Liquido	Liquid Line Solenoid Valve

# HYDRAULIC DIAGRAMS COOLBLADE CW-DW

size 16/16L/27/27L

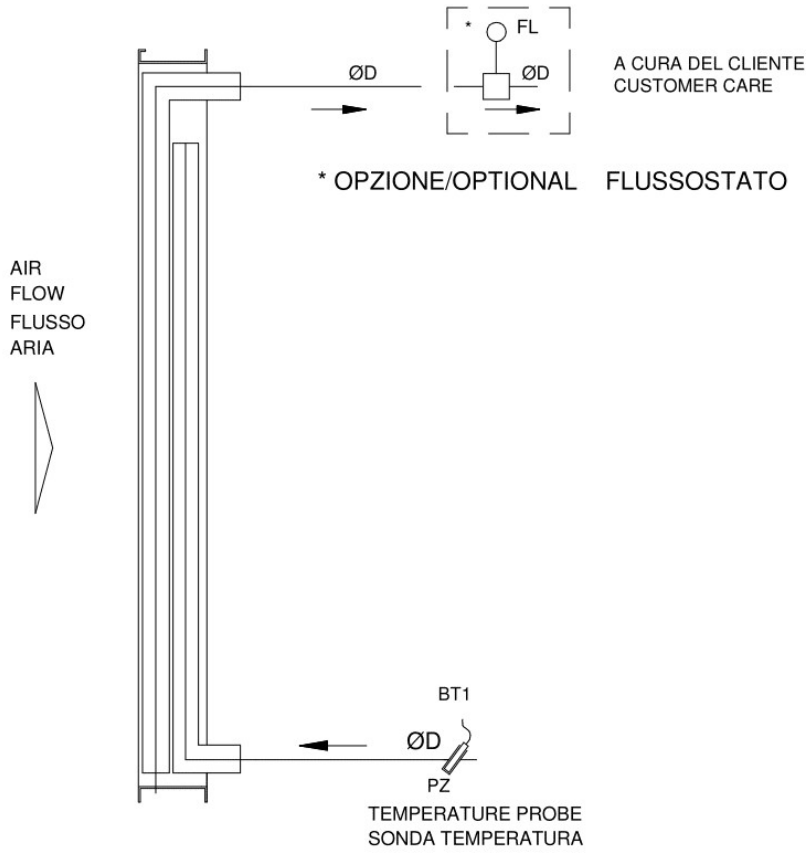

size 22/22L

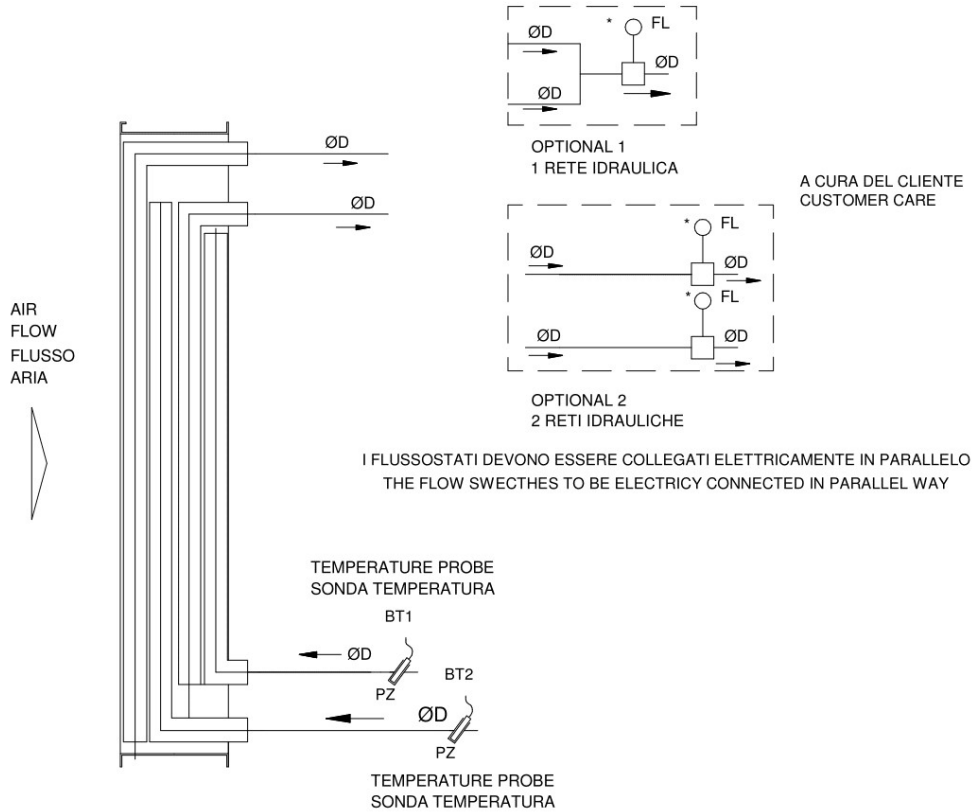

## OPERATING LIMITS – COOLBLADE DX

As concerns the combination of temperatures and relative humidities, it is strongly recommended that the design conditions of the return air (hot aisle) fall within the limits specified below:

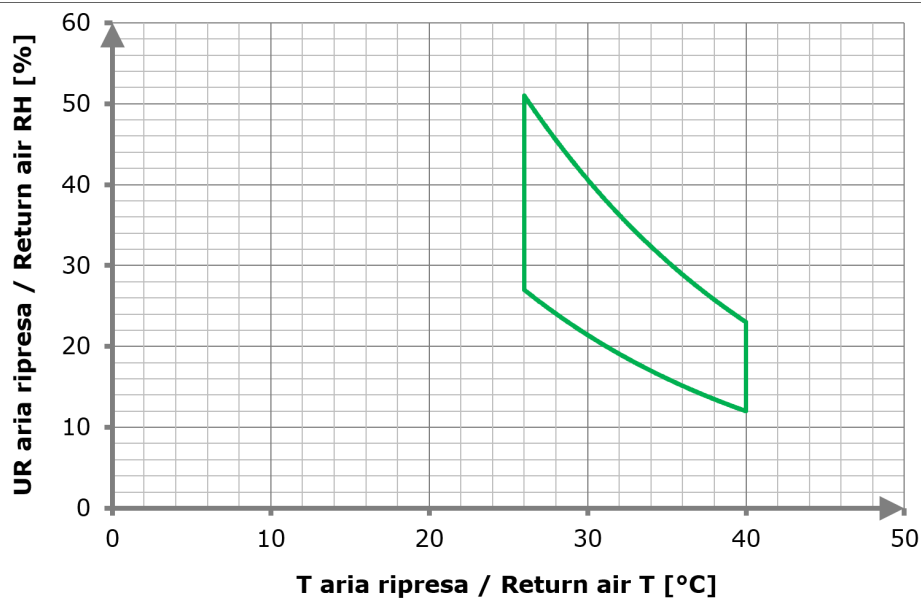

It should be emphasised that the standard design temperatures of a hot aisle/cold aisle system with containment are usually higher than 30°C; however, Coolblade DX units can also operate at lower return air temperatures, within the limits stated below.

### Coupled to Epsilon Echos + LE condensing unit

The operating limits indicated below are valid only for the standard coupling (see the “technical specifications” section).

### COOLBLADE DX - EPSILON ECHOS+ LE

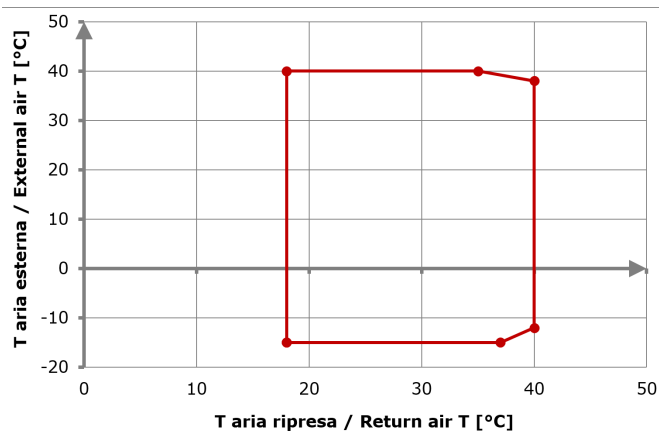

Condensing unit at maximum capacity (compressor at 120rps)

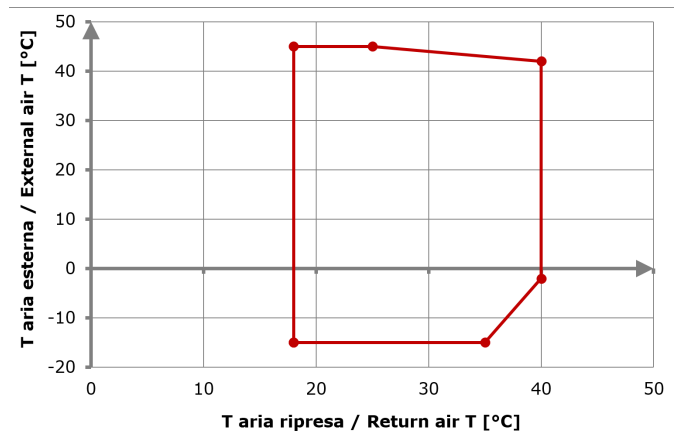

Condensing unit at rated capacity (compressor at 90rps)

## OPERATING LIMITS – COOLBLADE ED+

As concerns the combination of temperatures and relative humidities, it is strongly recommended that the design conditions of the return air (hot aisle) fall within the limits specified below:

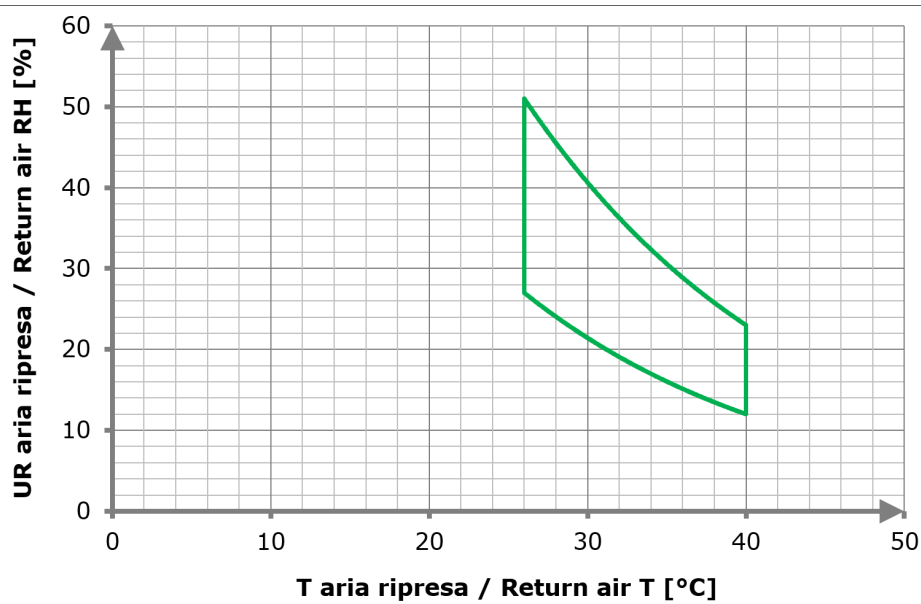

As concerns the combination of temperatures and relative humidities, it is strongly recommended that the design conditions of the return air (hot aisle) fall within the limits specified below:

## COOLBLADE ED+ - REMOTE CONDENSER RC GREEN

Below charts representing Coolblade limits based upon external temperatures, once coupled with RC Green remote air cooled condensers.

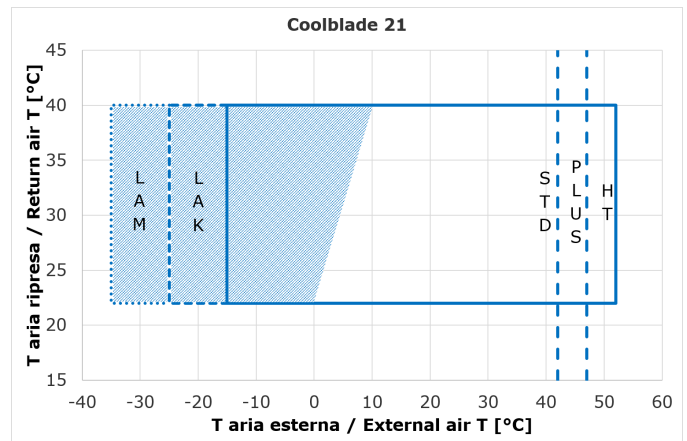
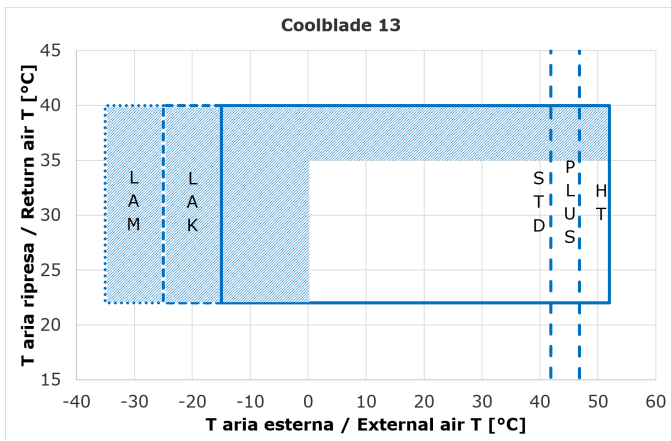

STD\_PLUS\_HT With condenser provided from Blue Box and fan speed regulator. Temperature limit is only an indication. The real value has to be verified using the selection Software (it varies based upon the load, working conditions, piping length)

LAK Low Ambient Kit for condensing control at low external temperature.

LAM Oversized Low Ambient Kit for condensing control at extremely low external temperature.

On shaded areas compressor might limit its fan speed due to working envelope control, in such case cooling capacity will be reduced.

## OPERATING LIMITS – COOLBLADE CW-DW

As concerns the combination of temperatures and relative humidities, it is strongly recommended that the design conditions of the return air (hot aisle) fall within the limits specified below:

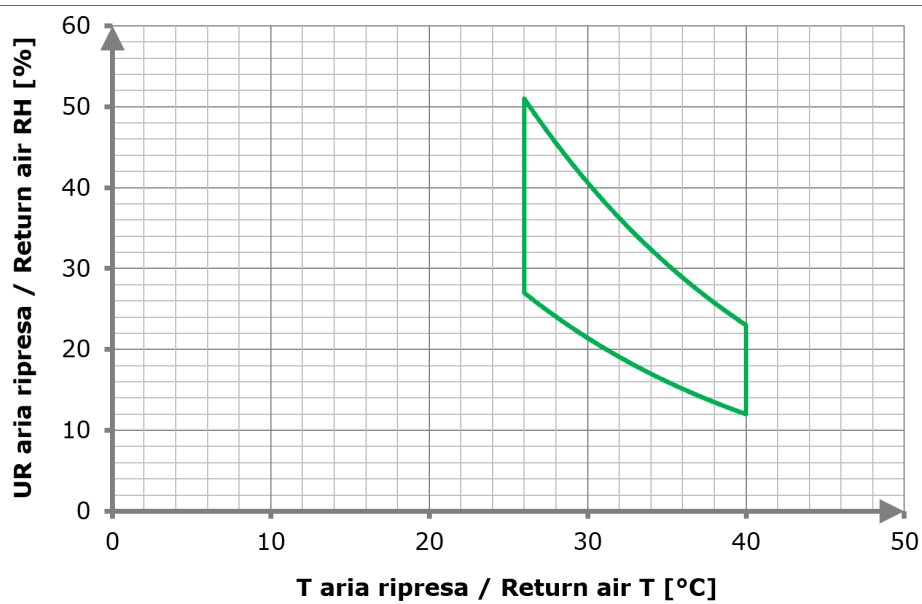

It should be emphasised that the standard design temperatures of a hot aisle/cold aisle system with containment are usually higher than 30°C; however, Coolblade CW-DW units can also operate at lower return air temperatures, within the limits stated below.

The operating limits indicated below refer to the optimal operation of the units. Outside the indicated limits, undesirable condensate and dehumidification problems, high head losses on hydraulic side or insufficient heat exchange may occur.

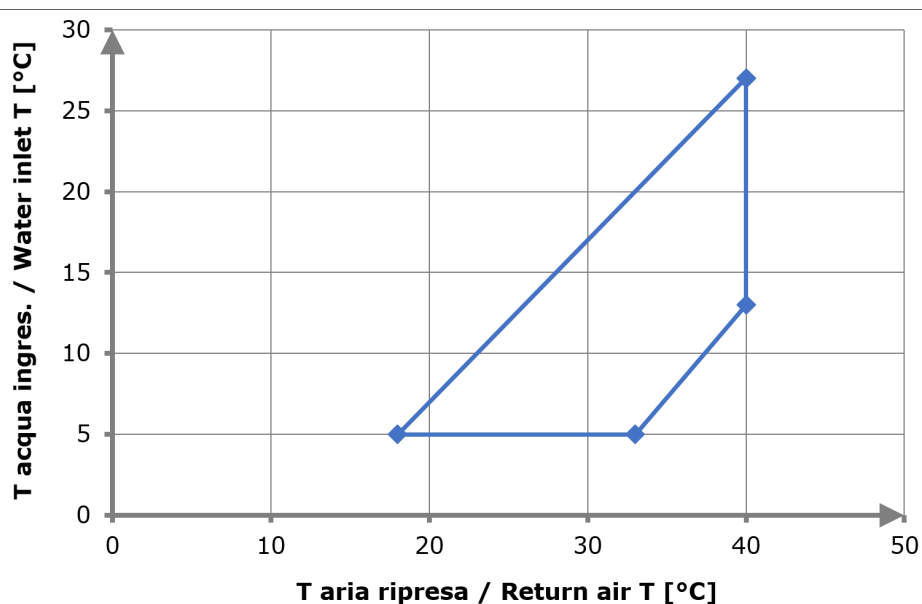

The maximum percentage of glycol is 50%.



# DIMENSIONAL DIAGRAMS

## COOLBLADE DX A - AXIAL FANS DEPTH 1000

DDIM000640 - A

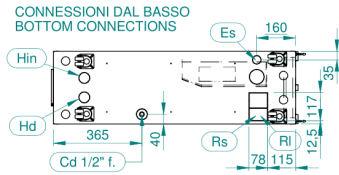
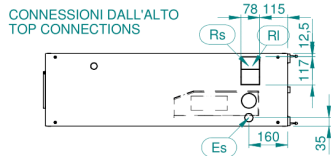
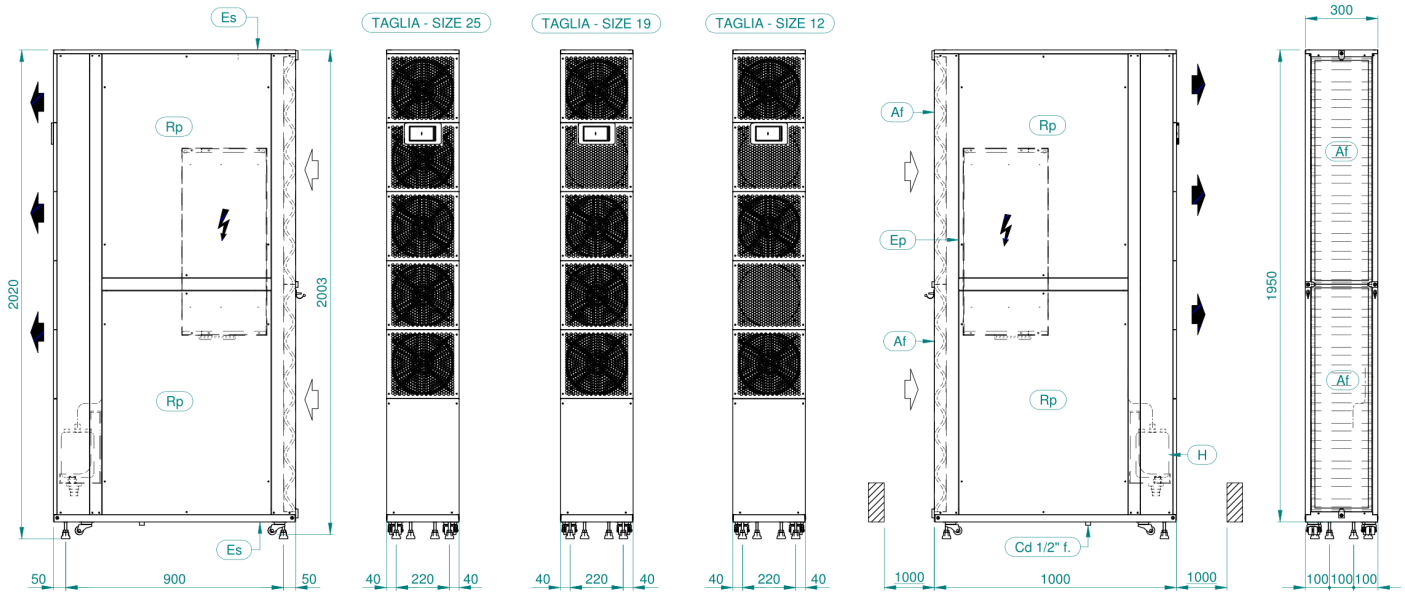

# COOLBLADE DX A - AXIAL FANS DEPTH 1200

DDIM000647 - A

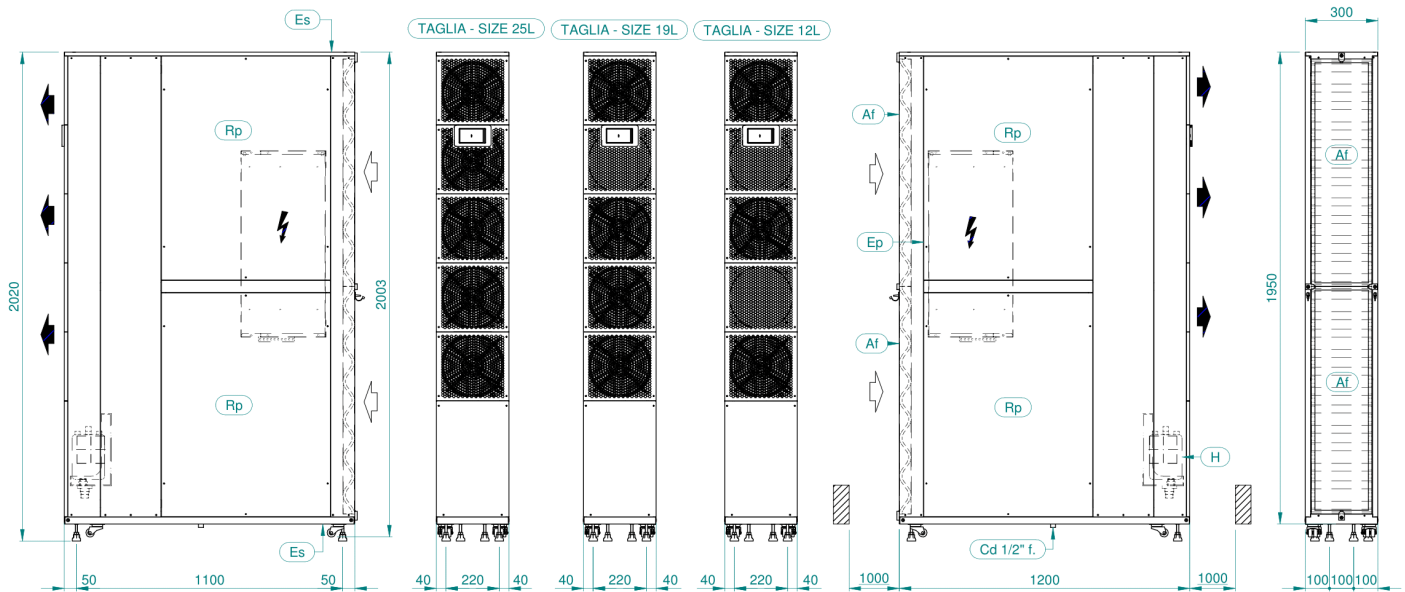

CONNESSIONI DALL'ALTO  
TOP CONNECTIONS

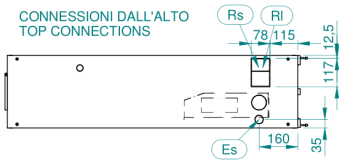

CONNESSIONI DAL BASSO  
BOTTOM CONNECTIONS

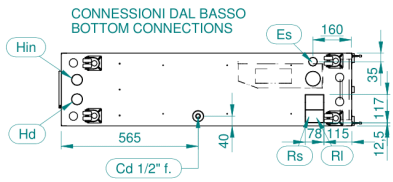

# COOLBLADE DX R - RADIAL FANS DEPTH 1000 (AIR DELIVERY FROM BOTH SIDES)

DDIM000643 - A

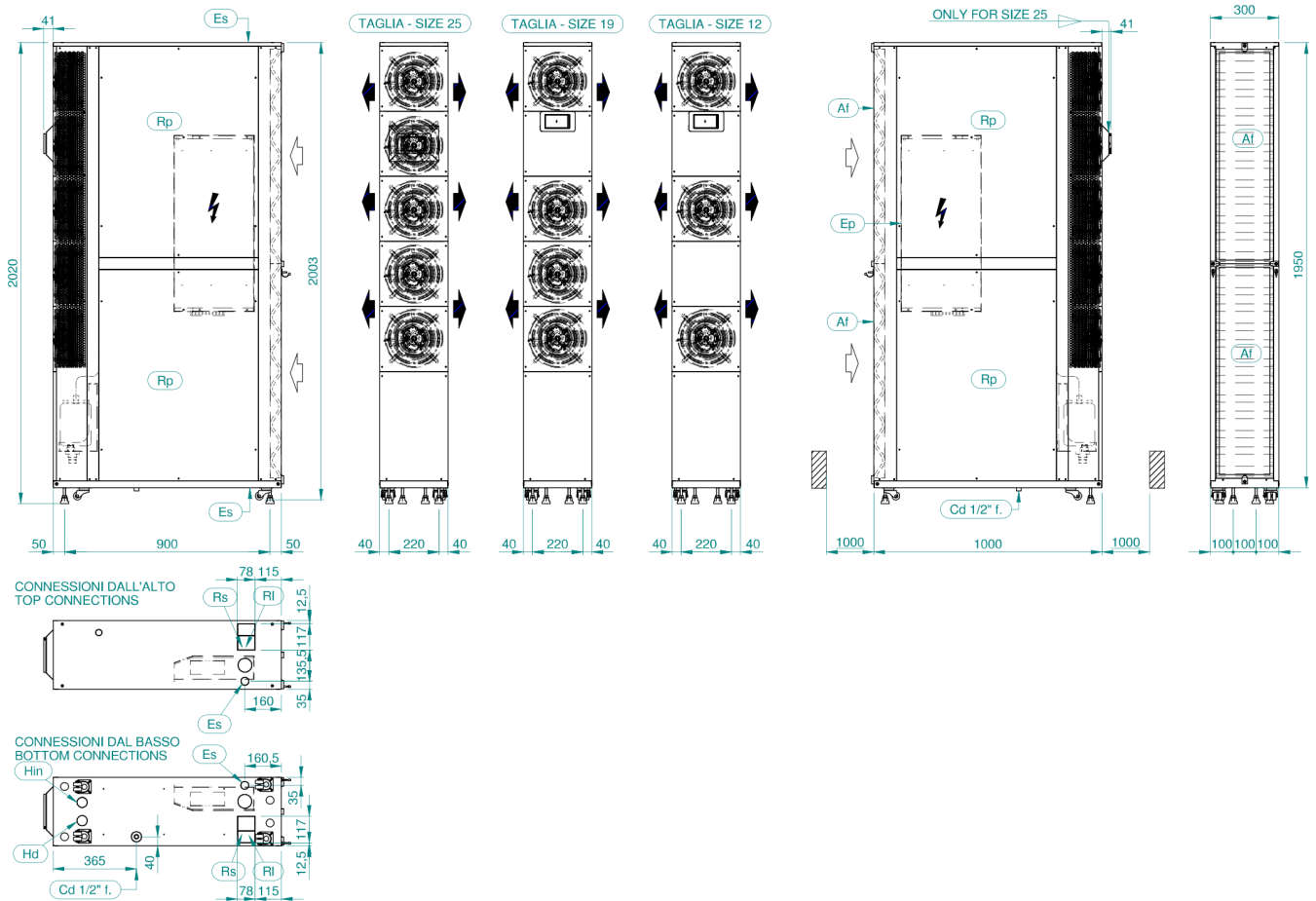

# COOLBLADE DX RR - RADIAL FANS DEPTH 1000 (AIR DELIVERY FROM THE RIGHT)

DDIM000643 - A

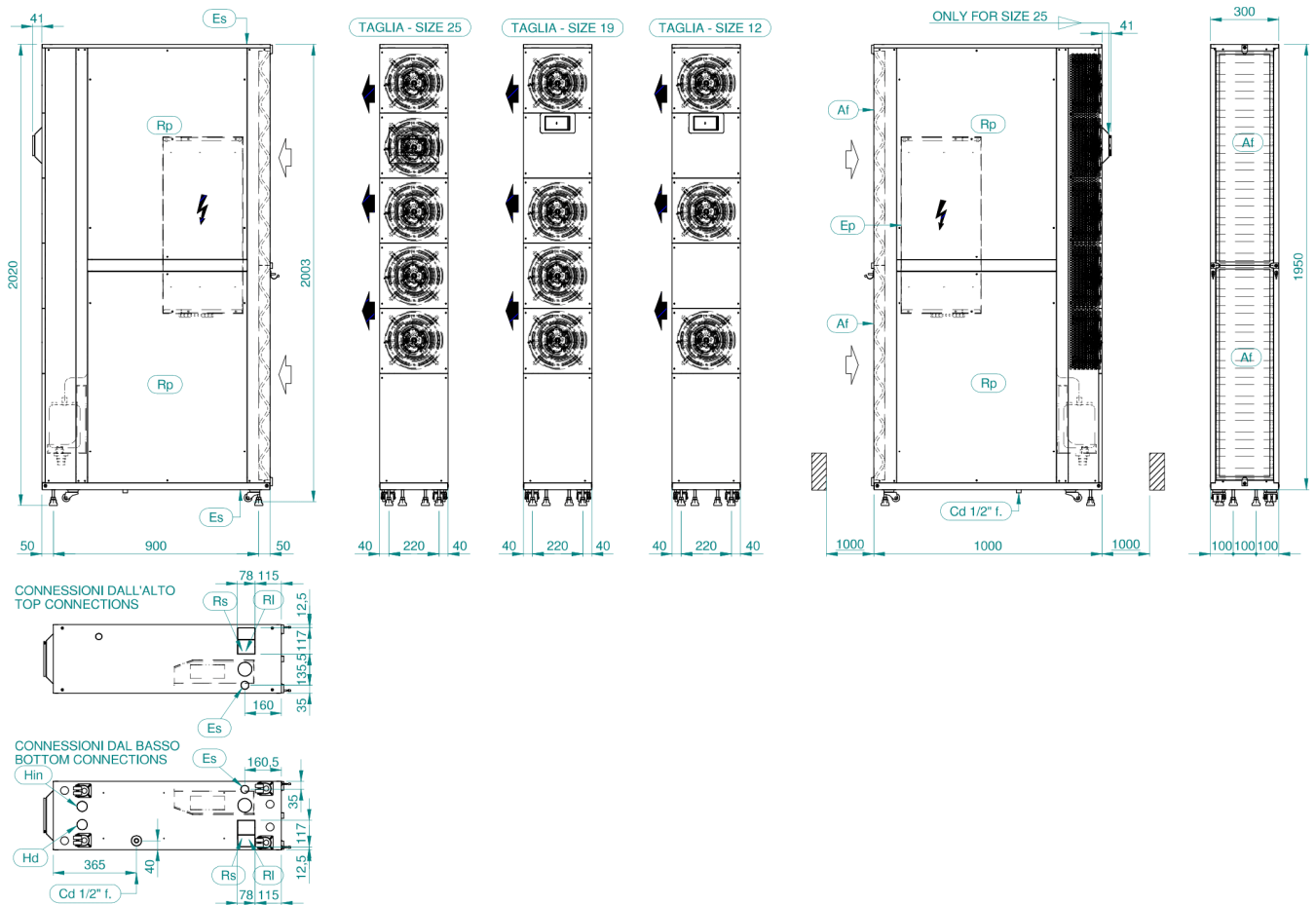

Warning! The air exhaust side is the one as seen looking at the unit from the top, orienting the unit according to the path of the air flow inside it.

# COOLBLADE DX RL - RADIAL FANS DEPTH 1000 (AIR DELIVERY FROM THE LEFT)

DDIM000643 - A

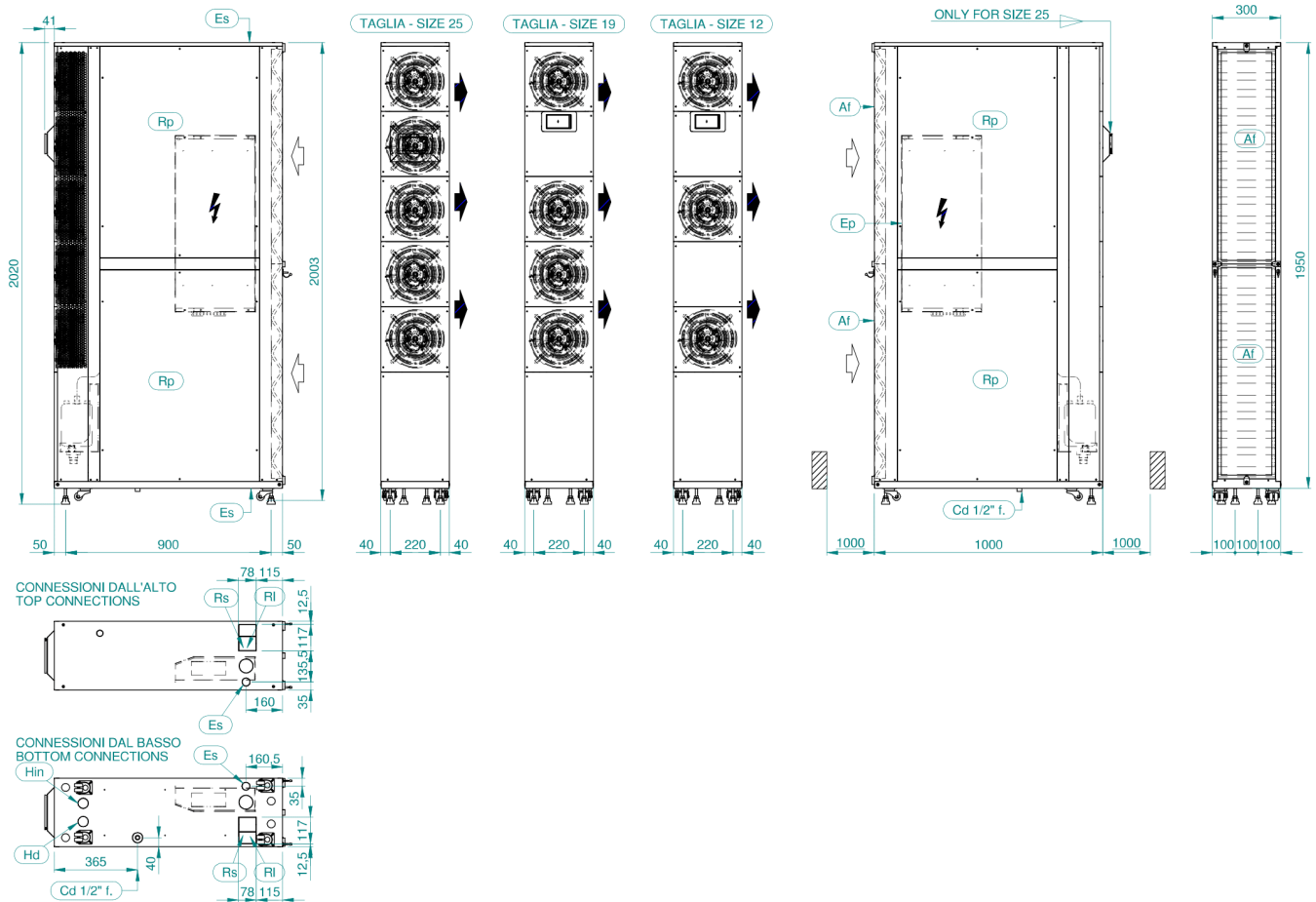

Warning! The air exhaust side is the one as seen looking at the unit from the top, orienting the unit according to the path of the air flow inside it.

# COOLBLADE DX R - RADIAL FANS DEPTH 1200 (AIR DELIVERY FROM BOTH SIDES)

DDIM000648 - A

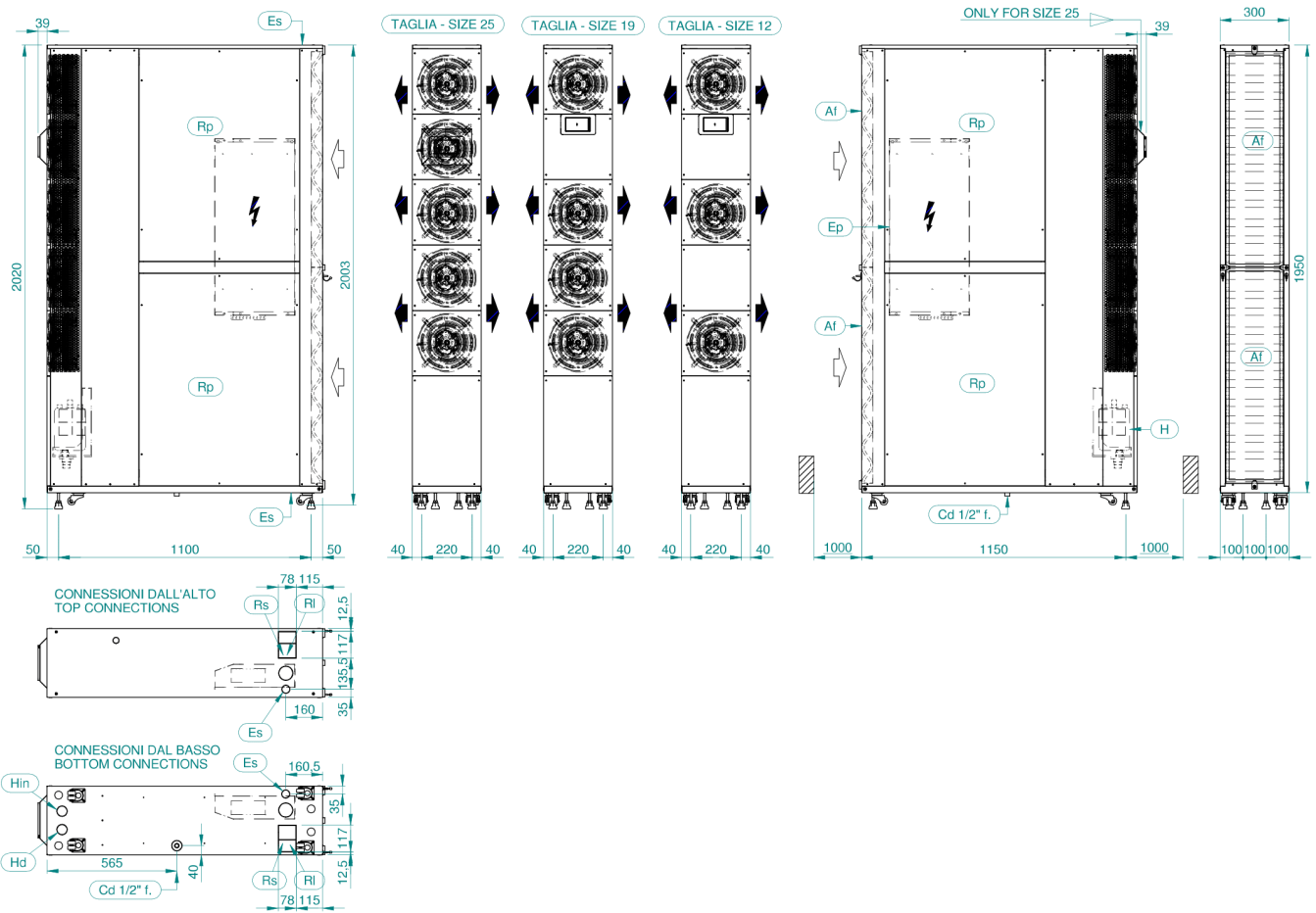

# COOLBLADE DX RR - RADIAL FANS DEPTH 1200 (AIR DELIVERY FROM THE RIGHT)

DDIM000648 - A

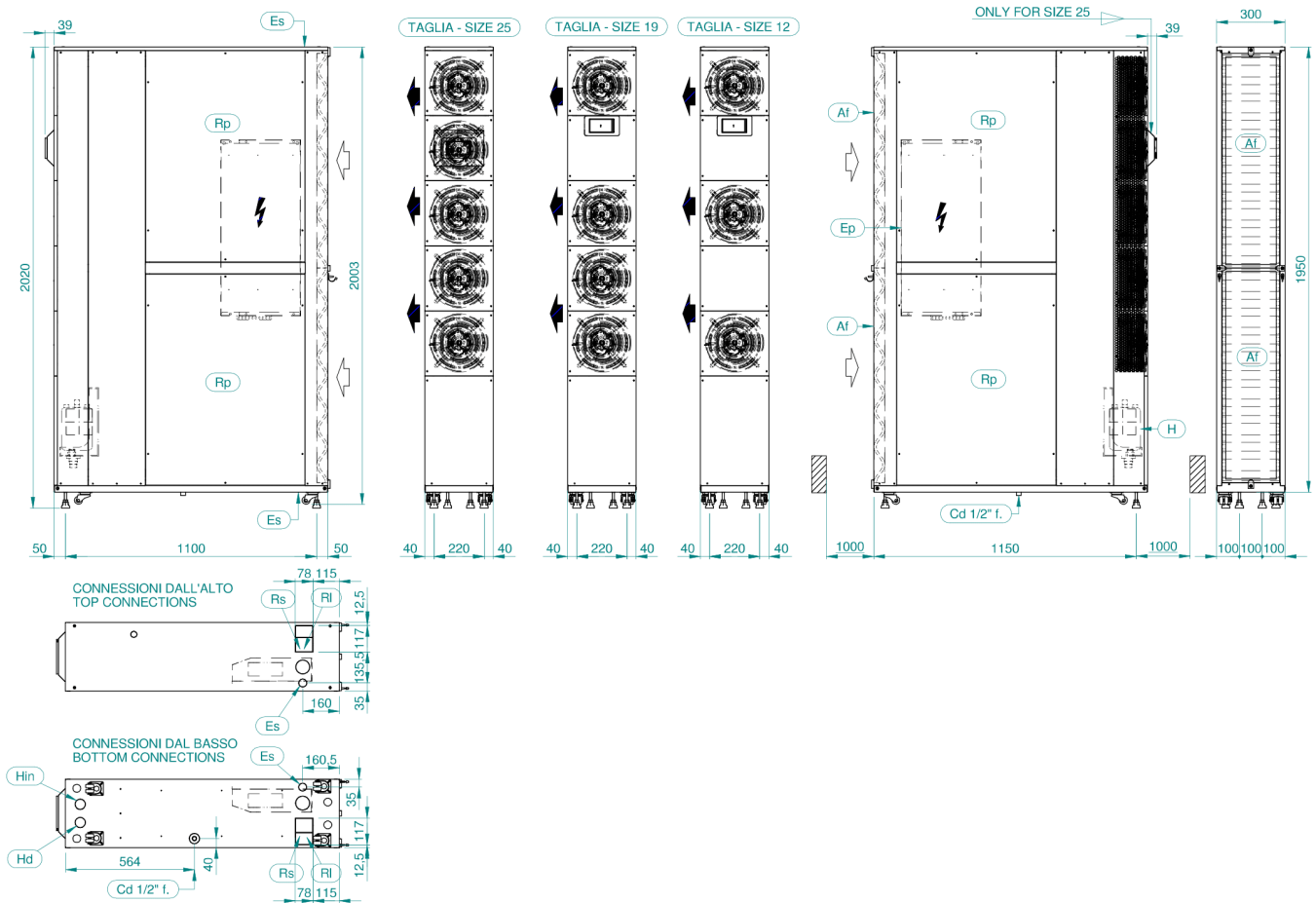

Warning! The air exhaust side is the one as seen looking at the unit from the top, orienting the unit according to the path of the air flow inside it.





# COOLBLADE ED+ A - AXIAL FANS DEPTH 1000

DDIM000375 - A

CONNESSIONI DAL BASSO  
BOTTOM CONNECTIONS

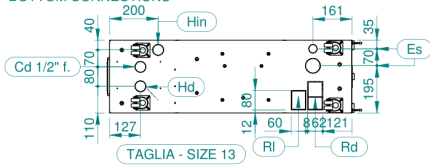

TAGLIA - SIZE 13

TAGLIA - SIZE 21

TAGLIA - SIZE 21

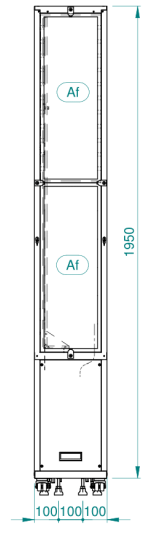
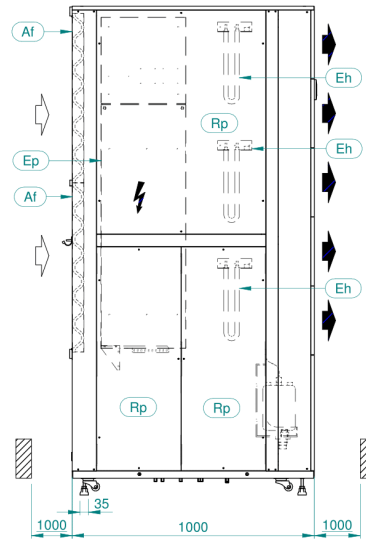
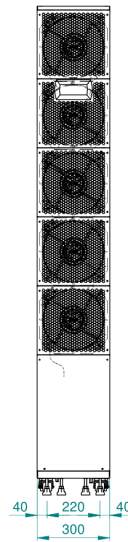
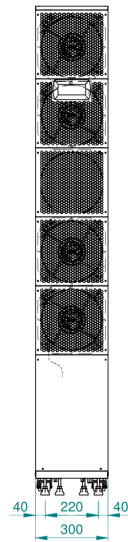
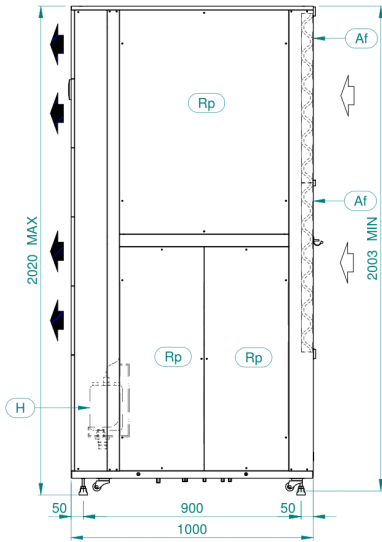

\*OPTIONAL Pu/Cd/Hd drain

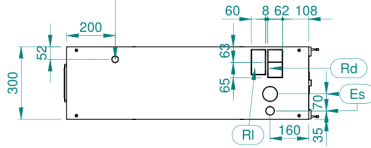

CONNESSIONI DALL'ALTO  
TOP CONNECTIONS

# COOLBLADE ED+ A - AXIAL FANS DEPTH 1200

DDIM000381 - A

CONNESSIONI DAL BASSO  
BOTTOM CONNECTIONS

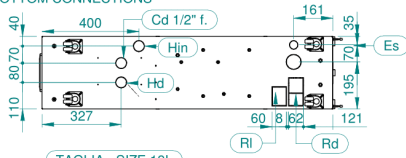

TAGLIA - SIZE 13L

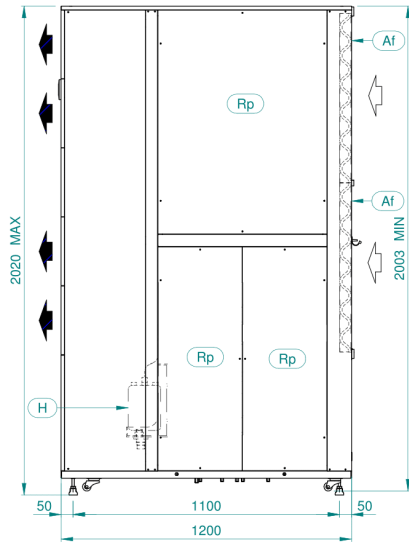

TAGLIA - SIZE 13L

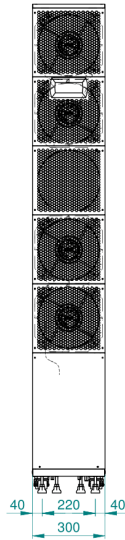

TAGLIA - SIZE 21L

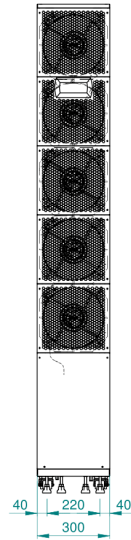

TAGLIA - SIZE 21L

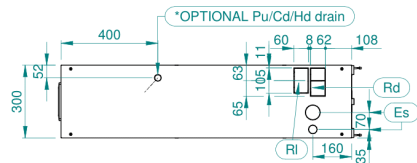
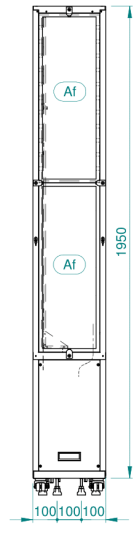
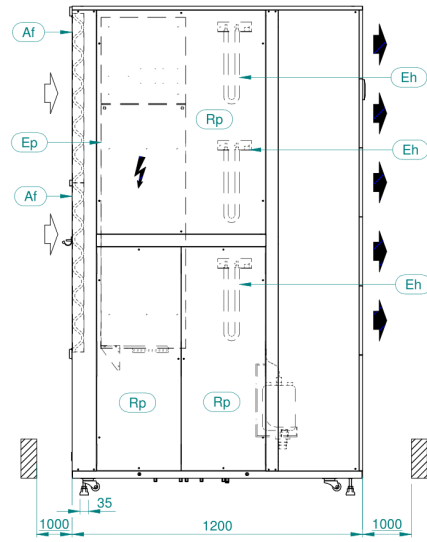

CONNESSIONI DALL'ALTO  
TOP CONNECTIONS

# COOLBLADE ED+ R - RADIAL FANS DEPTH 1000 (AIR DELIVERY FROM BOTH SIDES)

DDIM000368 - A

CONNESSIONI DAL BASSO  
BOTTOM CONNECTIONS

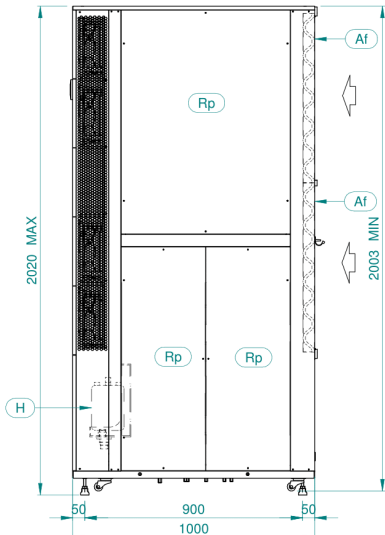
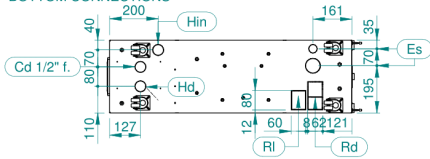

TAGLIA - SIZE 13

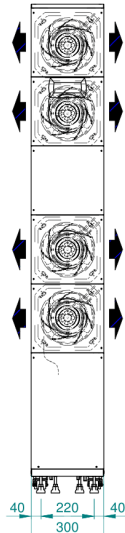

TAGLIA - SIZE 21

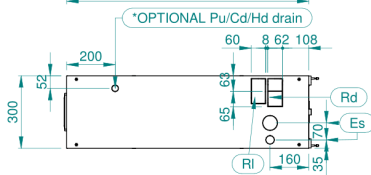
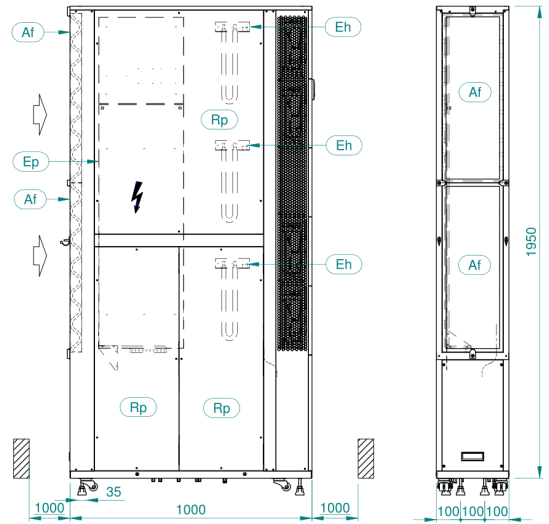
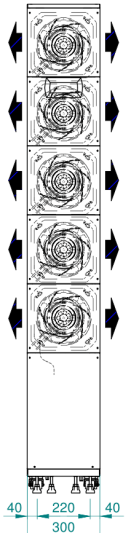

CONNESSIONI DALL'ALTO  
TOP CONNECTIONS

# COOLBLADE ED+ RR - RADIAL FANS DEPTH 1000 (AIR DELIVERY FROM THE RIGHT)

DDIM000368 - A

CONNESSIONI DAL BASSO  
BOTTOM CONNECTIONS

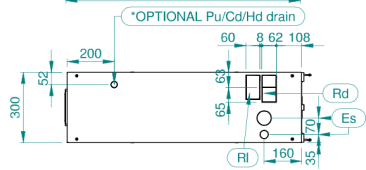
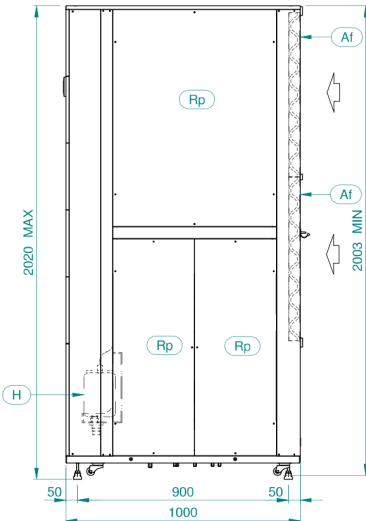
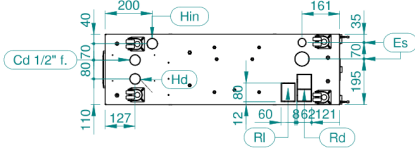

CONNESSIONI DALL'ALTO  
TOP CONNECTIONS

TAGLIA - SIZE 13

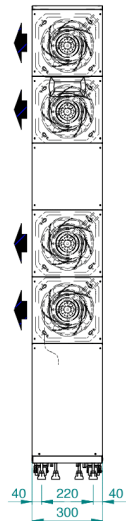

TAGLIA - SIZE 21

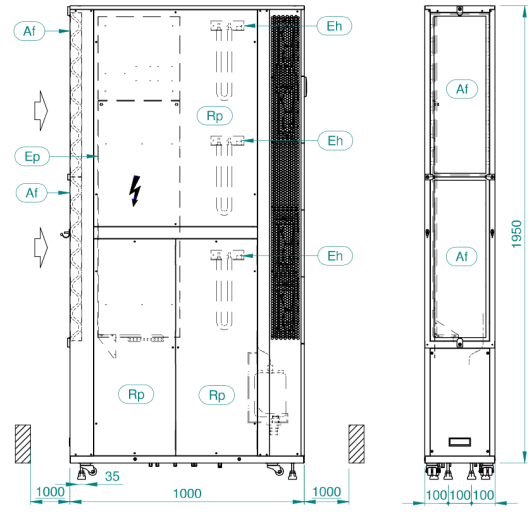
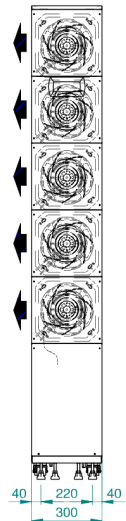

Warning! The air exhaust side is the one as seen looking at the unit from the top, orienting the unit according to the path of the air flow inside it.

# COOLBLADE ED+ RL - RADIAL FANS DEPTH 1000 (AIR DELIVERY FROM THE LEFT)

DDIM000368 - A

CONNESSIONI DAL BASSO  
BOTTOM CONNECTIONS

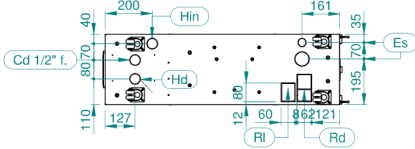

TAGLIA - SIZE 13

TAGLIA - SIZE 21

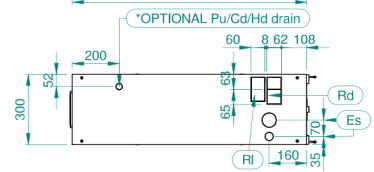
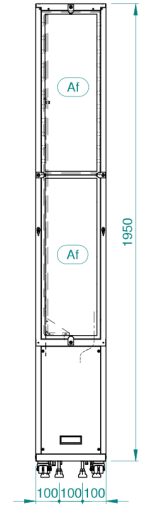
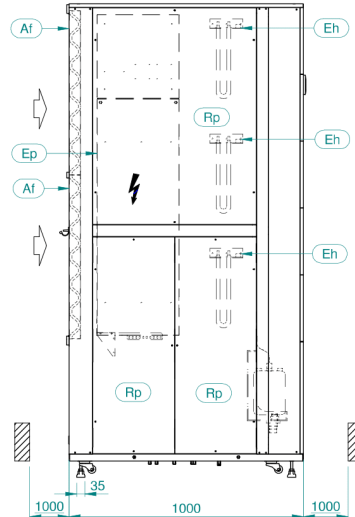
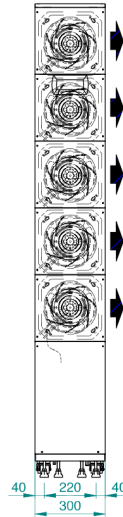
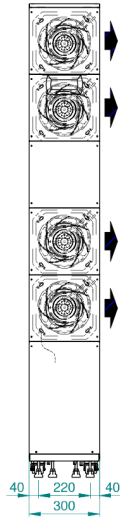
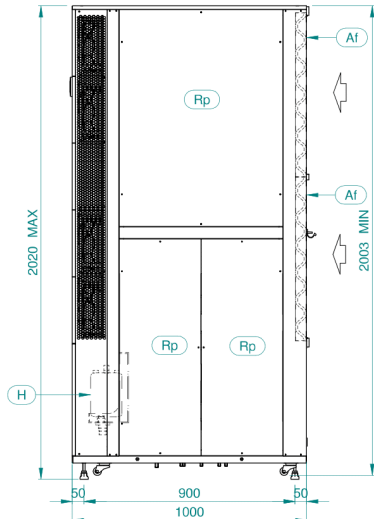

CONNESSIONI DALL'ALTO  
TOP CONNECTIONS

Warning! The air exhaust side is the one as seen looking at the unit from the top, orienting the unit according to the path of the air flow inside it.

# COOLBLADE ED+ R - RADIAL FANS DEPTH 1200 (AIR DELIVERY FROM BOTH SIDES)

DDIM000382 - A

CONNESSIONI DAL BASSO  
BOTTOM CONNECTIONS

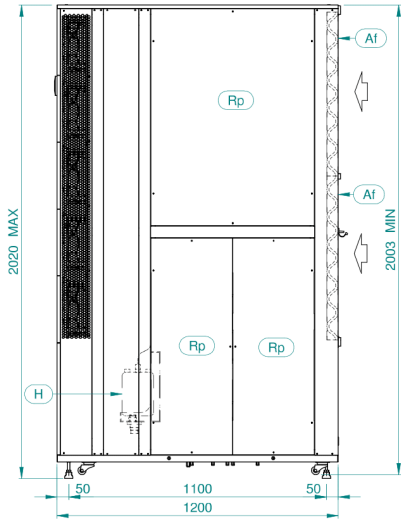
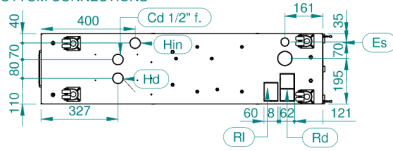

TAGLIA - SIZE 13L

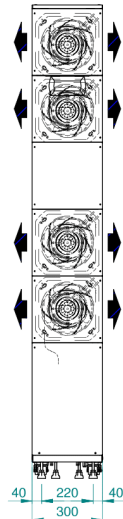

TAGLIA - SIZE 21L

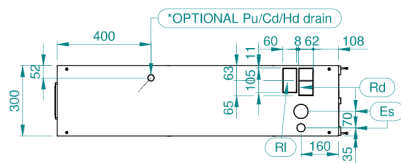
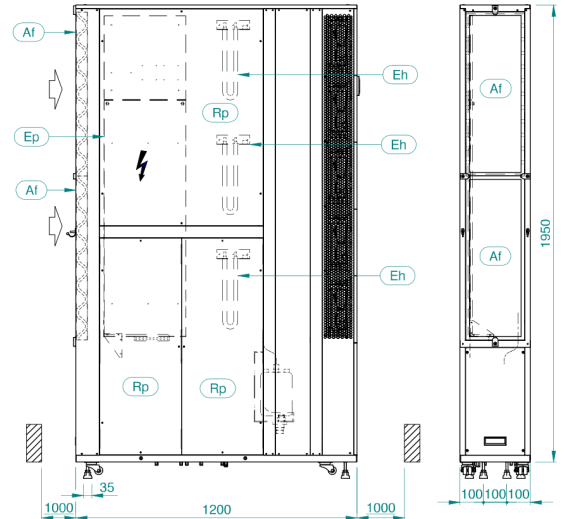
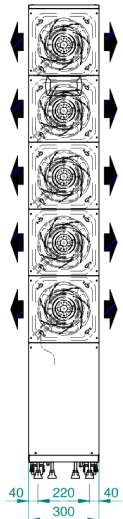

CONNESSIONI DALL'ALTO  
TOP CONNECTIONS



# COOLBLADE ED+ RR - RADIAL FANS DEPTH 1200 (AIR DELIVERY FROM THE RIGHT)

DDIM000382 - A

CONNESSIONI DAL BASSO  
BOTTOM CONNECTIONS

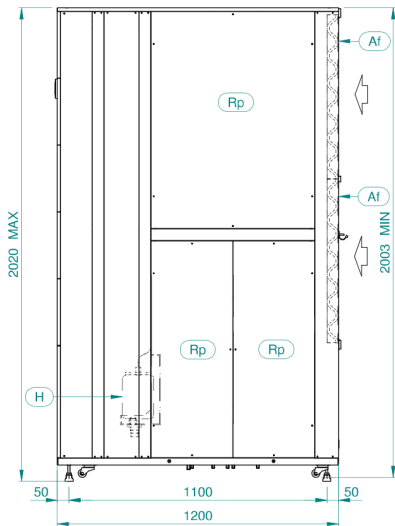
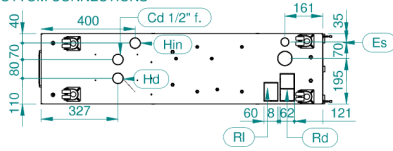

TAGLIA - SIZE 13L

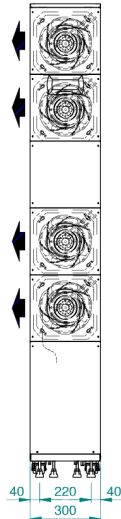

TAGLIA - SIZE 21L

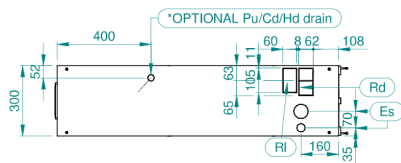
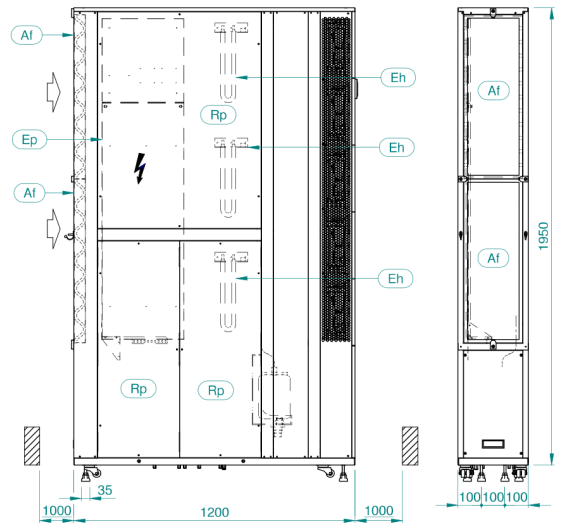
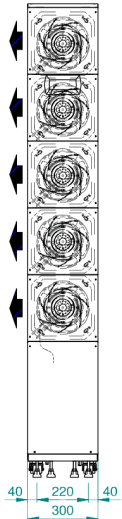

CONNESSIONI DALL'ALTO  
TOP CONNECTIONS

Warning! The air exhaust side is the one as seen looking at the unit from the top, orienting the unit according to the path of the air flow inside it.

# COOLBLADE ED+ RL - RADIAL FANS DEPTH 1200 (AIR DELIVERY FROM THE LEFT)

DDIM000382 - A

CONNESSIONI DAL BASSO  
BOTTOM CONNECTIONS

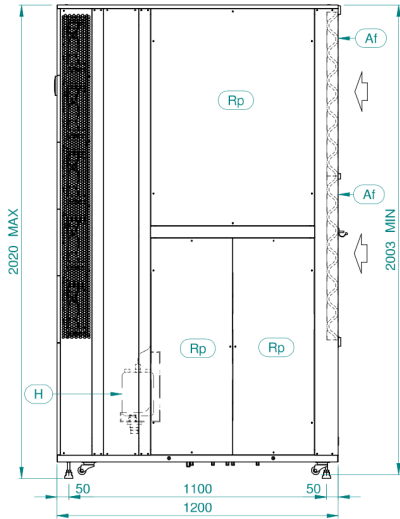
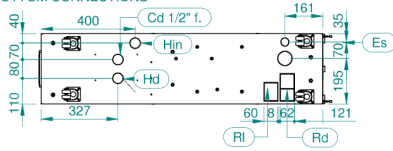

TAGLIA - SIZE 13L

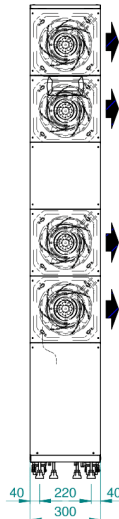

TAGLIA - SIZE 21L

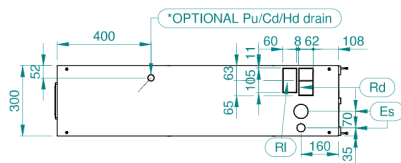
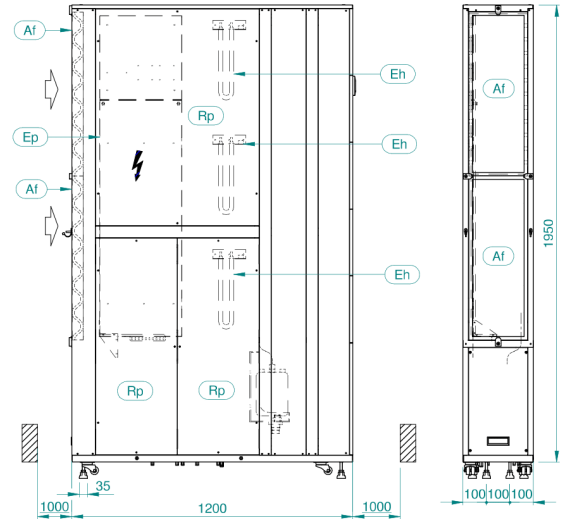
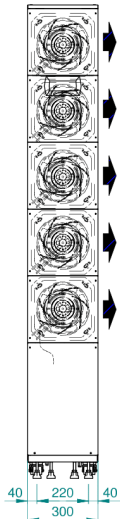

CONNESSIONI DALL'ALTO  
TOP CONNECTIONS

Warning! The air exhaust side is the one as seen looking at the unit from the top, orienting the unit according to the path of the air flow inside it.

# COOLBLADE CW DW A - AXIAL FANS DEPTH 1000

DDIM000644 - A

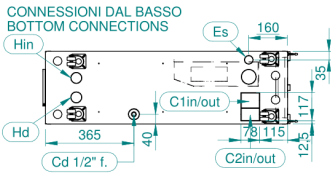
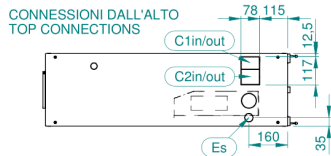
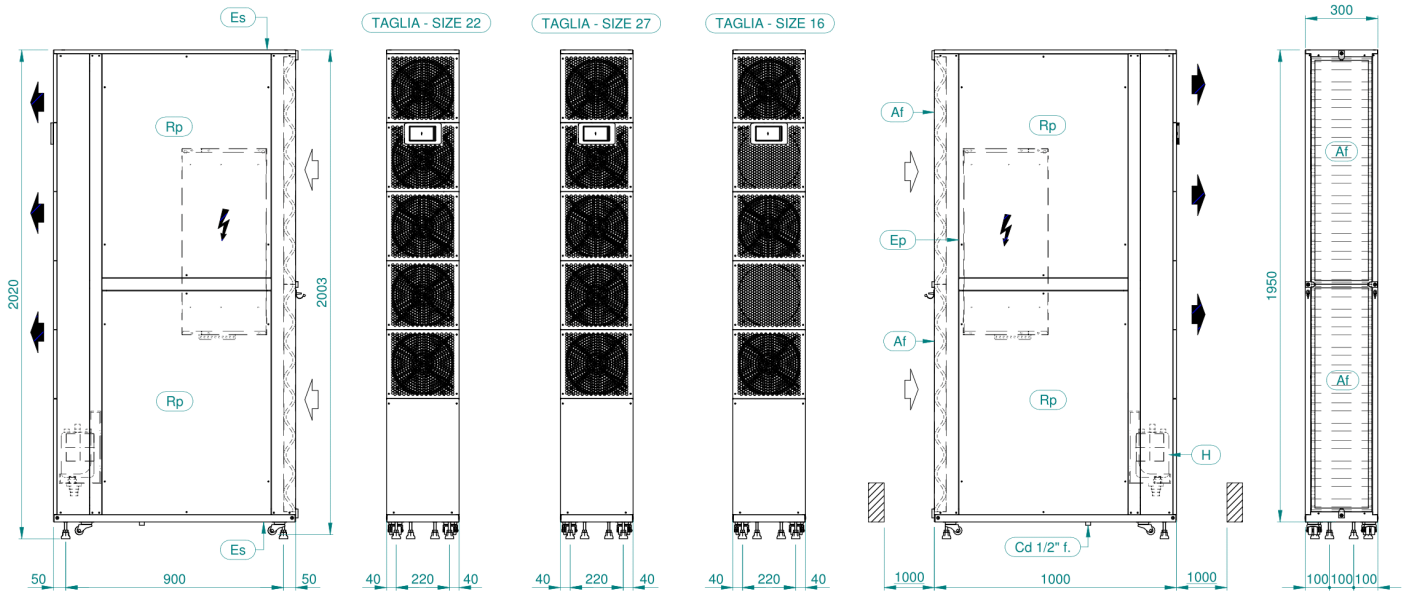

# COOLBLADE CW DW A - AXIAL FANS DEPTH 1200

DDIM000649 - A

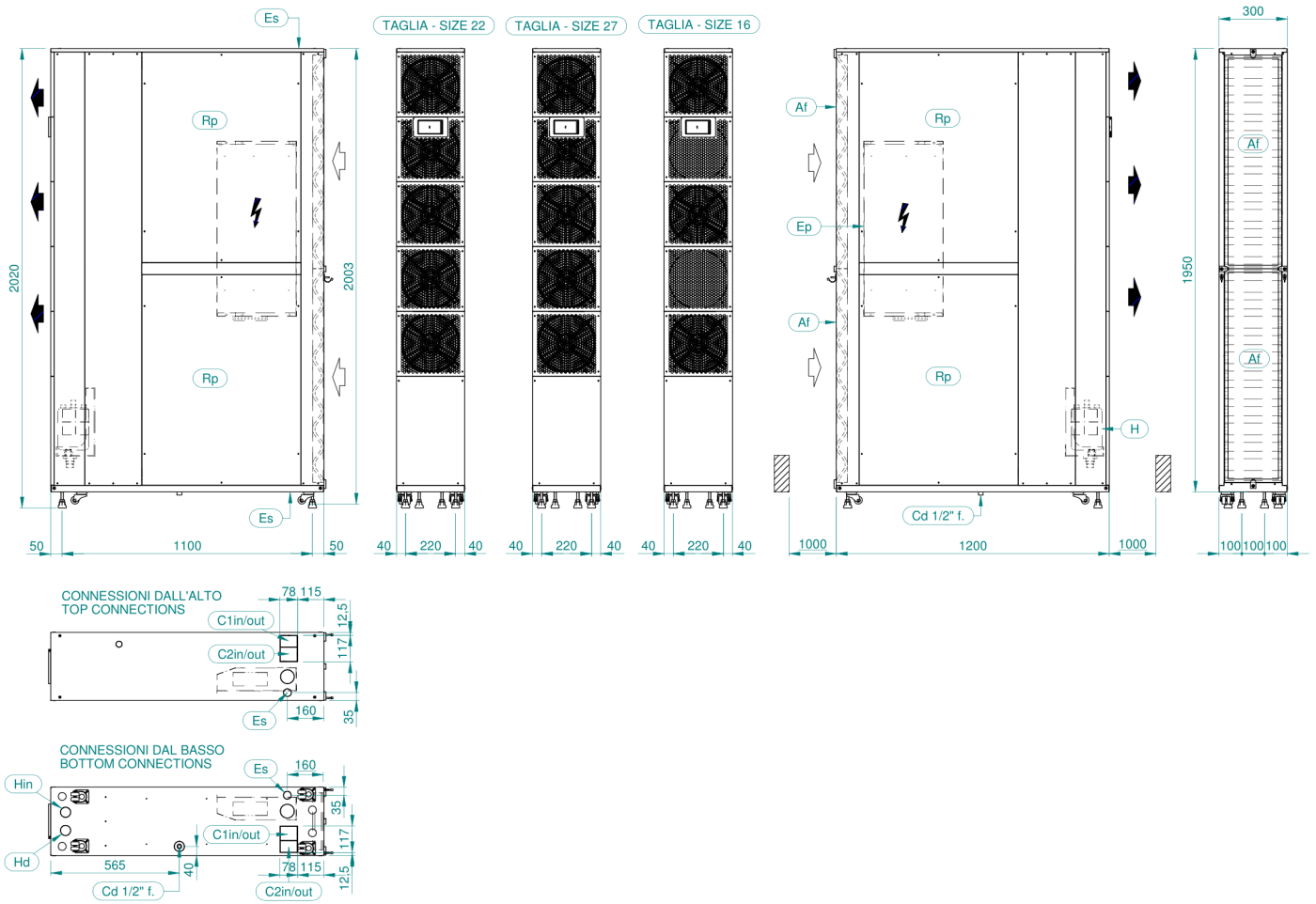

# COOLBLADE CW DW R - RADIAL FANS DEPTH 1000

DDIM000646 - A

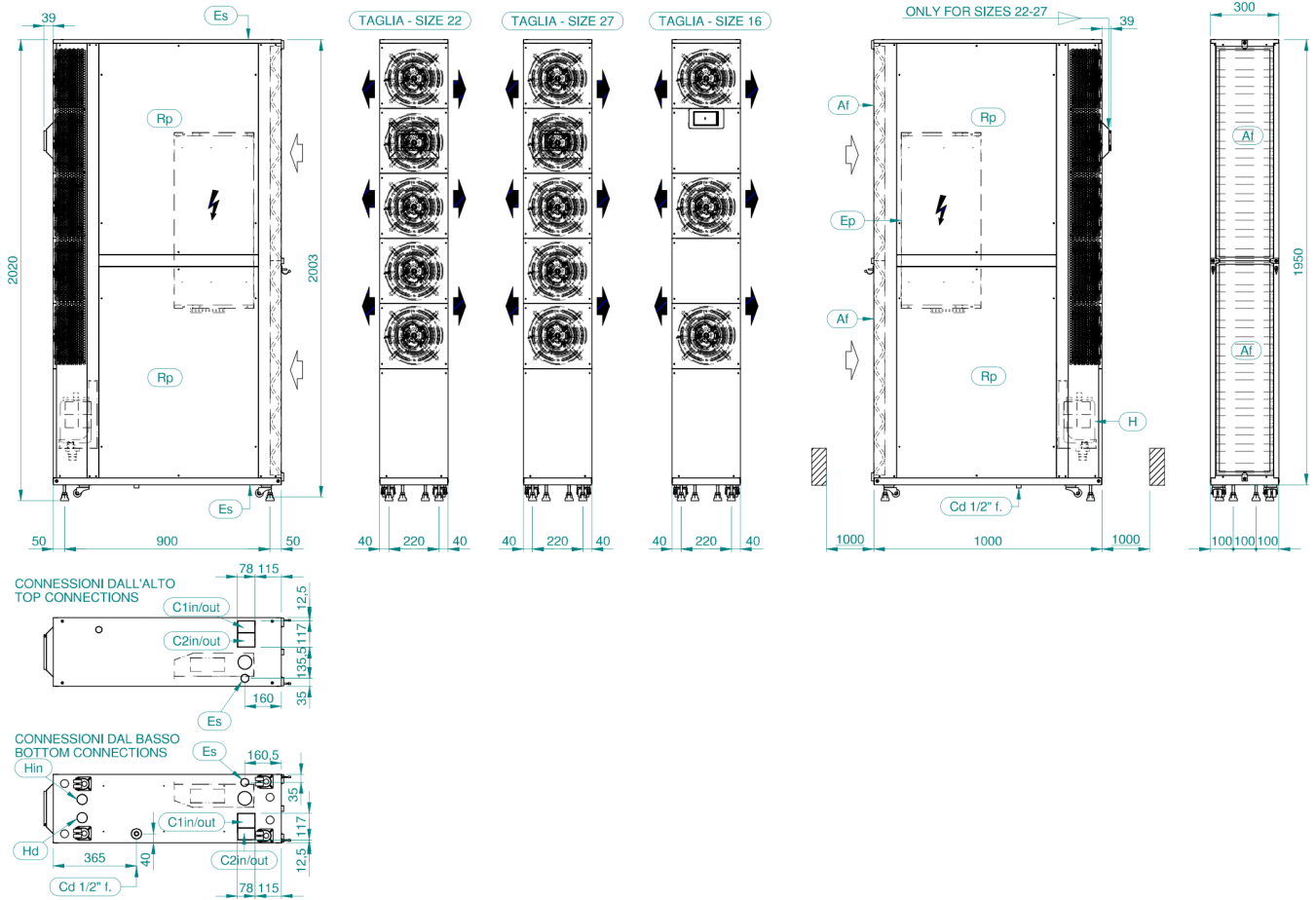

# COOLBLADE CW DW RR - RADIAL FANS DEPTH 1000

DDIM000646 - A

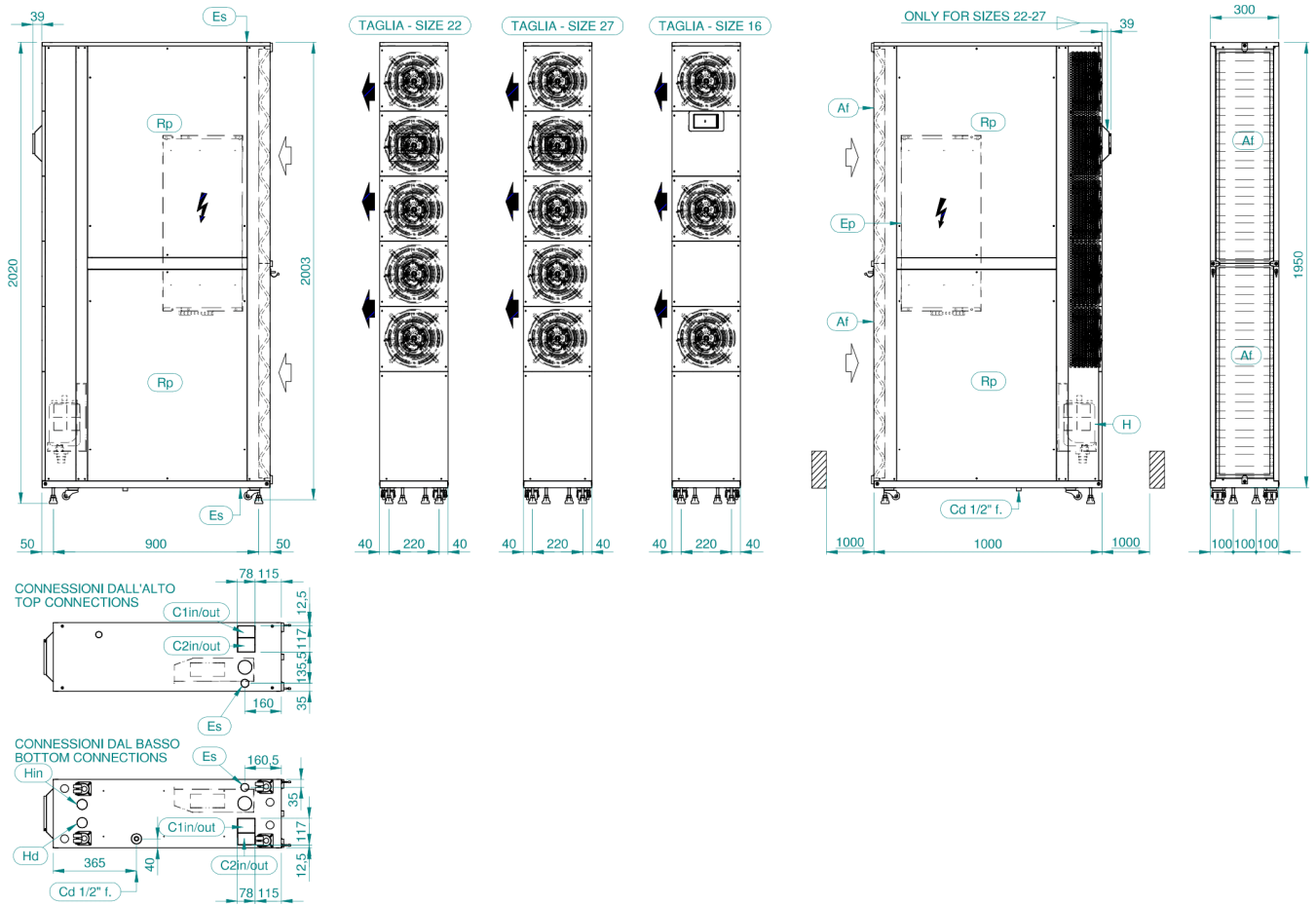

Warning! The air exhaust side is the one as seen looking at the unit from the top, orienting the unit according to the path of the air flow inside it.

# COOLBLADE CW DW RL - RADIAL FANS DEPTH 1000

DDIM000646 - A

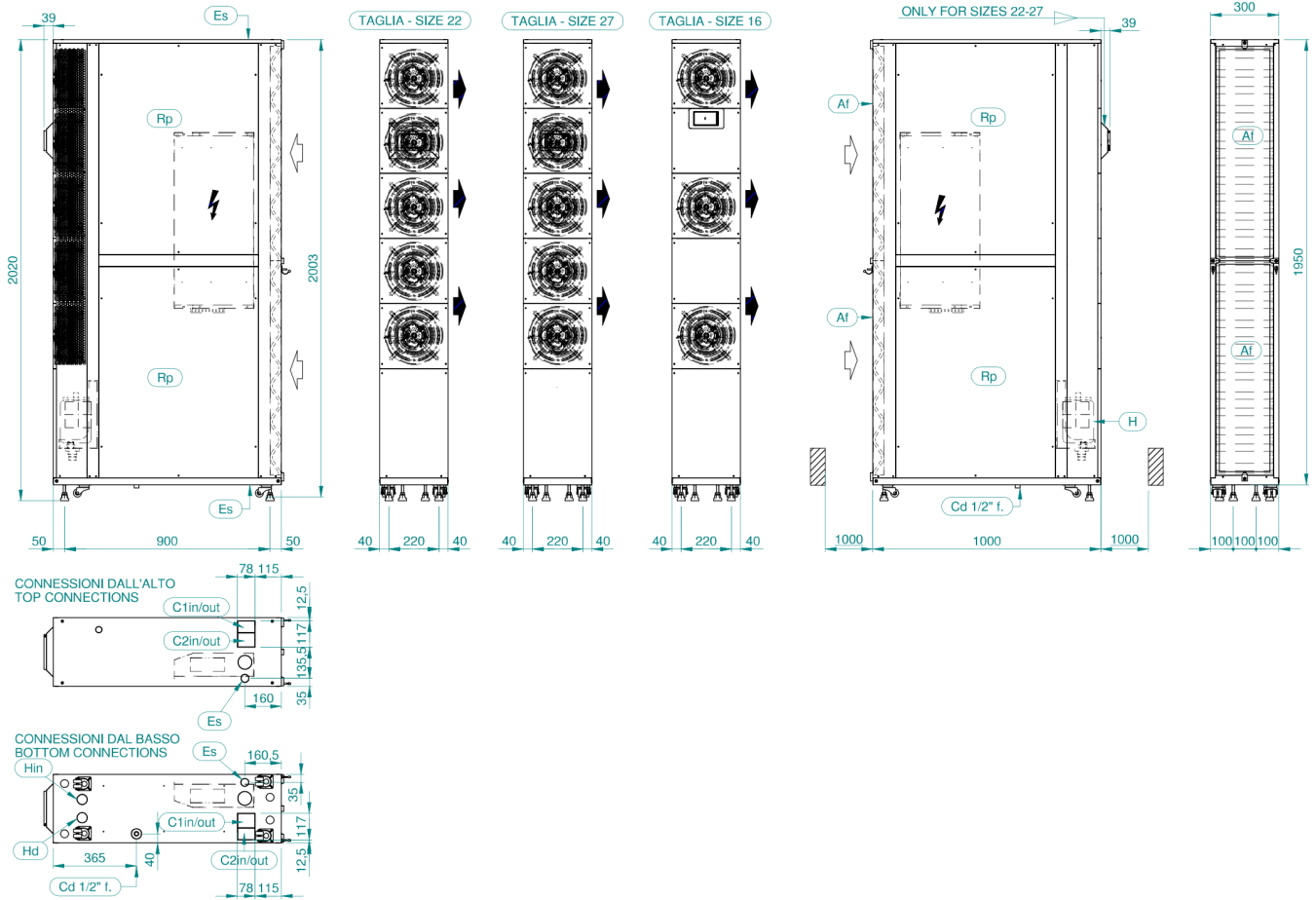

Warning! The air exhaust side is the one as seen looking at the unit from the top, orienting the unit according to the path of the air flow inside it.



# COOLBLADE CW DW R - RADIAL FANS DEPTH 1200

DDIM000650 - A

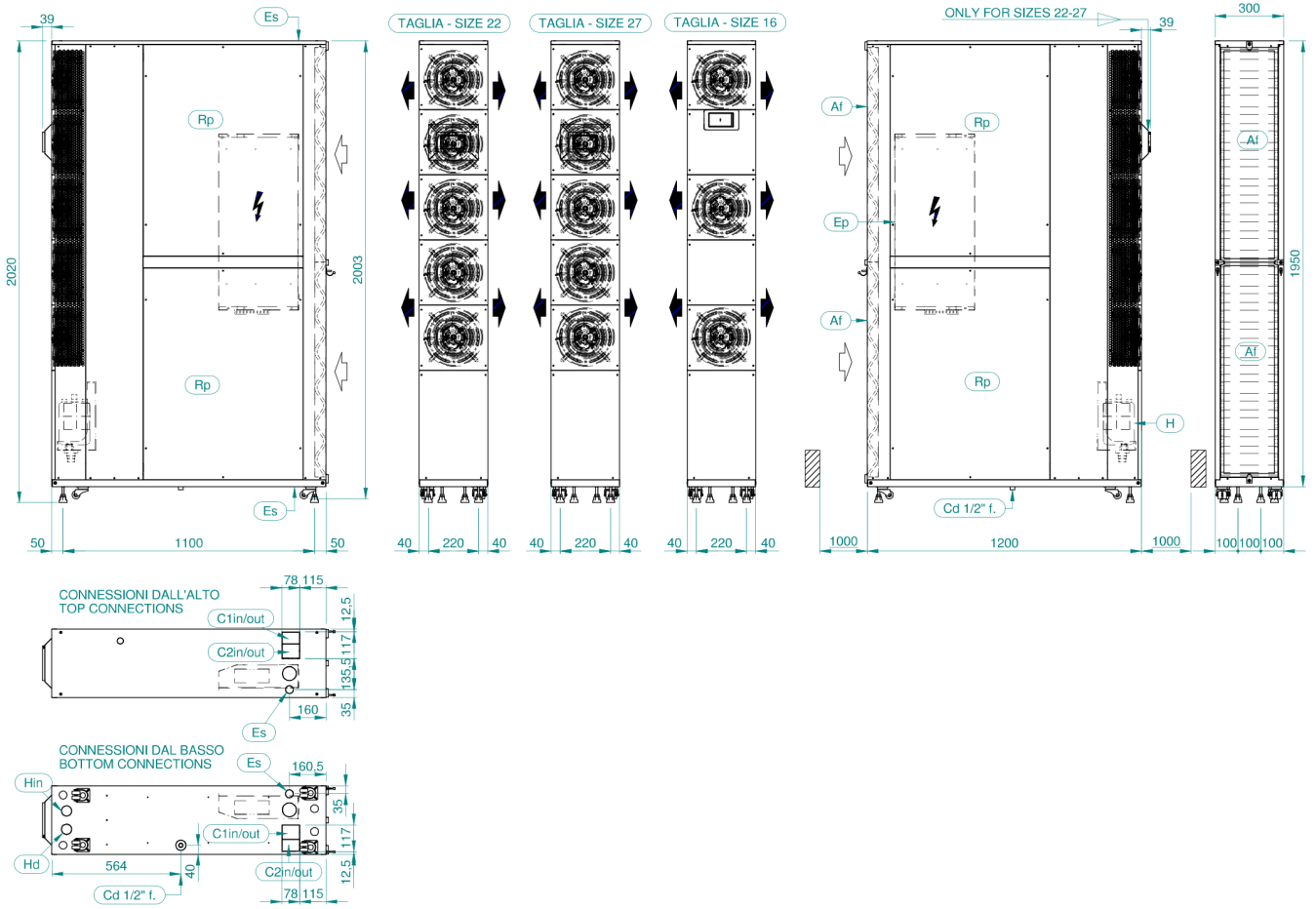

# COOLBLADE CW DW RR - RADIAL FANS DEPTH 1200

DDIM000650 - A

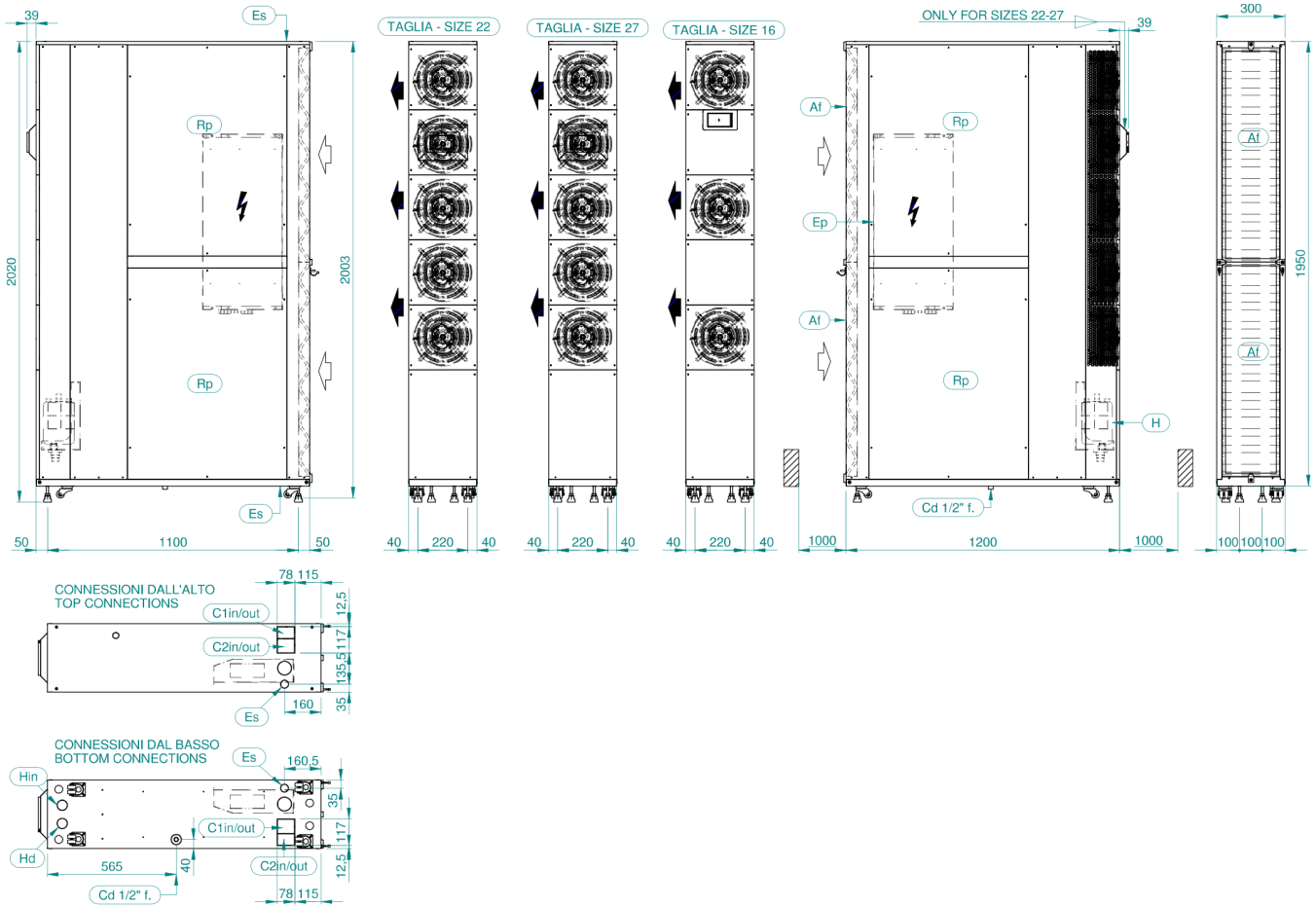

Warning! The air exhaust side is the one as seen looking at the unit from the top, orienting the unit according to the path of the air flow inside it.

# COOLBLADE CW DW RL - RADIAL FANS DEPTH 1200

DDIM000650 - A

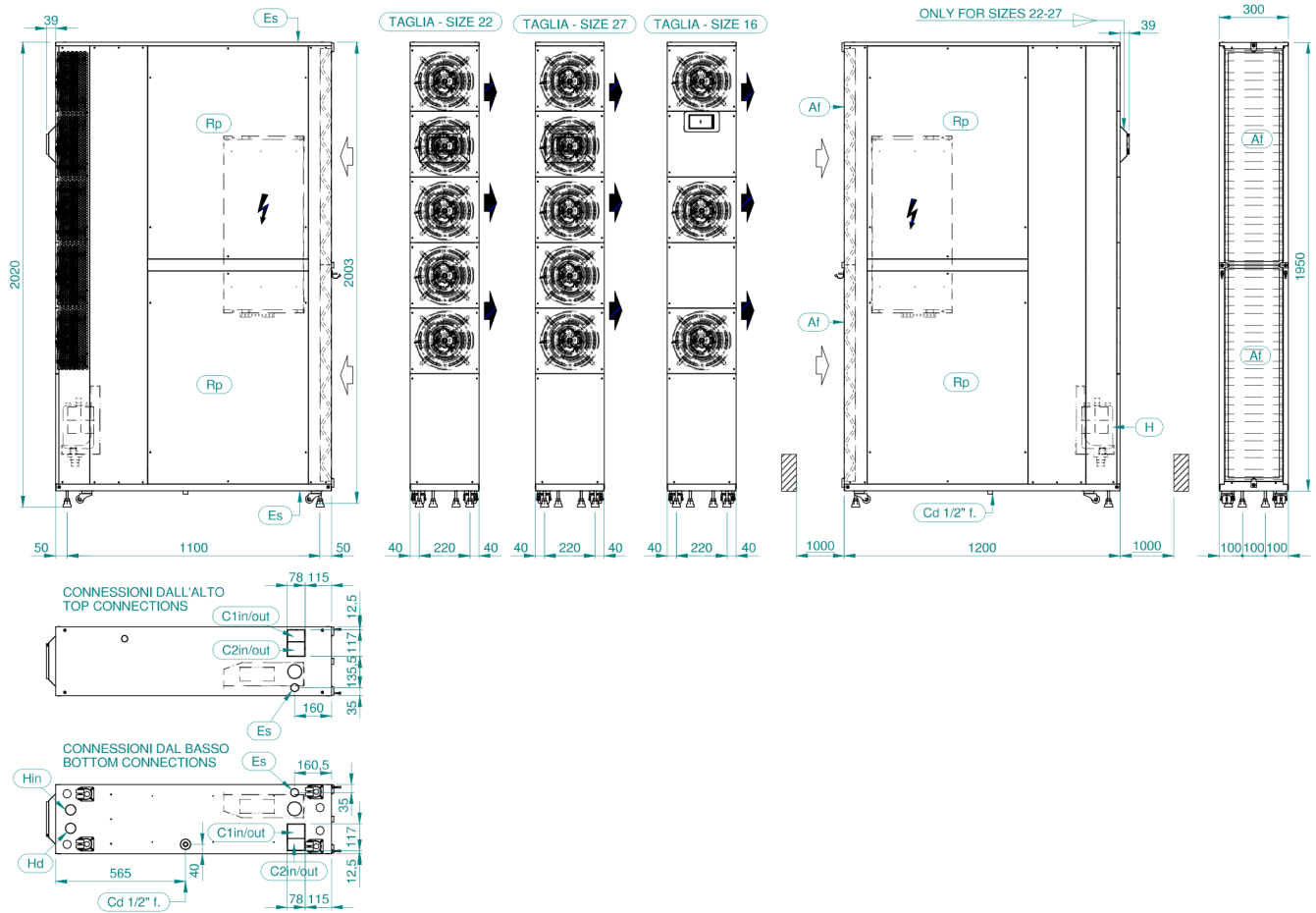

Warning! The air exhaust side is the one as seen looking at the unit from the top, orienting the unit according to the path of the air flow inside it.

# COOLBLADE CW 36 R - RADIAL FANS DEPTH 1200

DDIM000654 - A

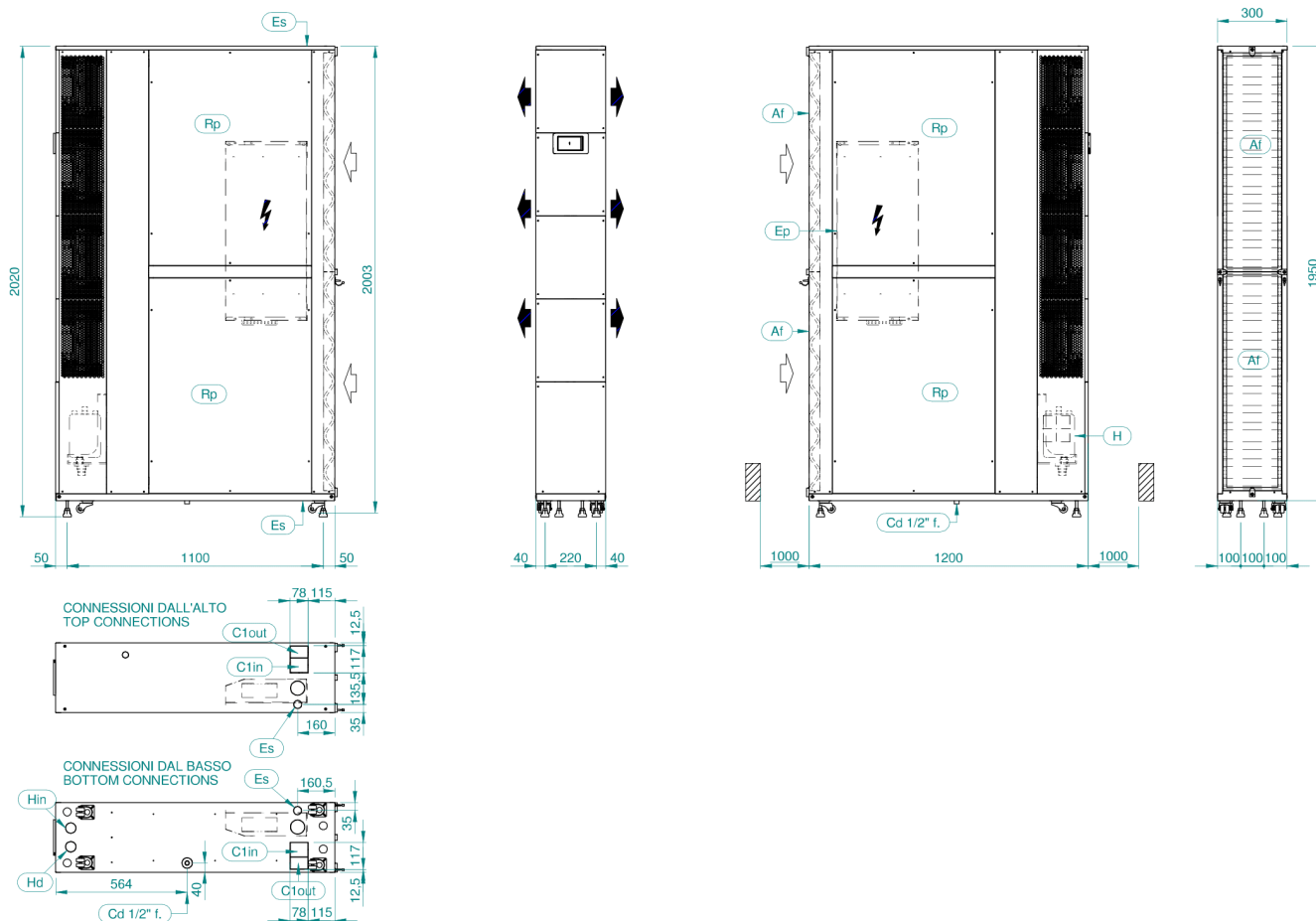

Warning! The air exhaust side is the one as seen looking at the unit from the top, orienting the unit according to the path of the air flow inside it.

# COOLBLADE CW 36 RR - RADIAL FANS DEPTH 1200

DDIM000654 - A

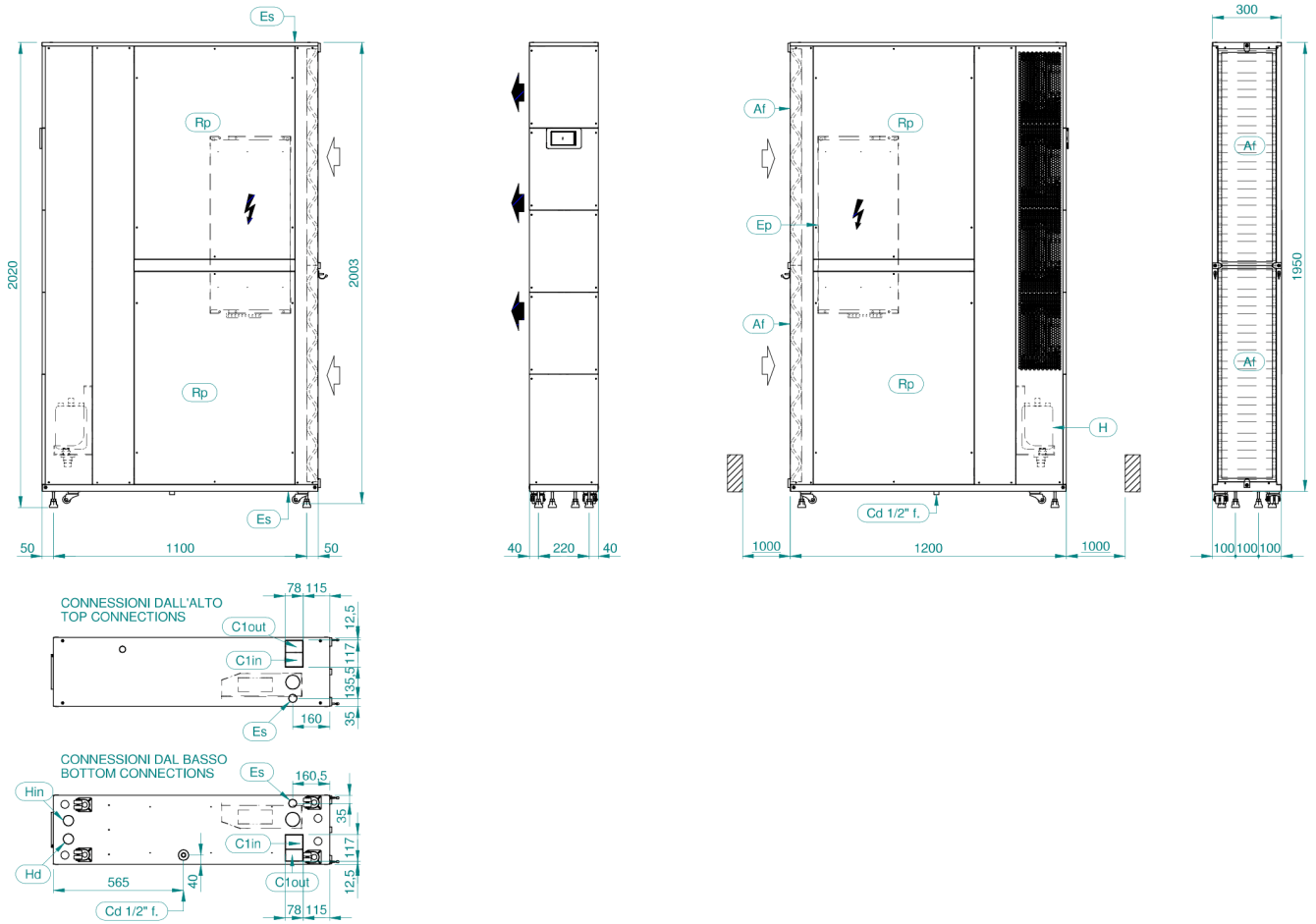

Warning! The air exhaust side is the one as seen looking at the unit from the top, orienting the unit according to the path of the air flow inside it.

# COOLBLADE CW 36 RL - RADIAL FANS DEPTH 1200

DDIM000654 - A

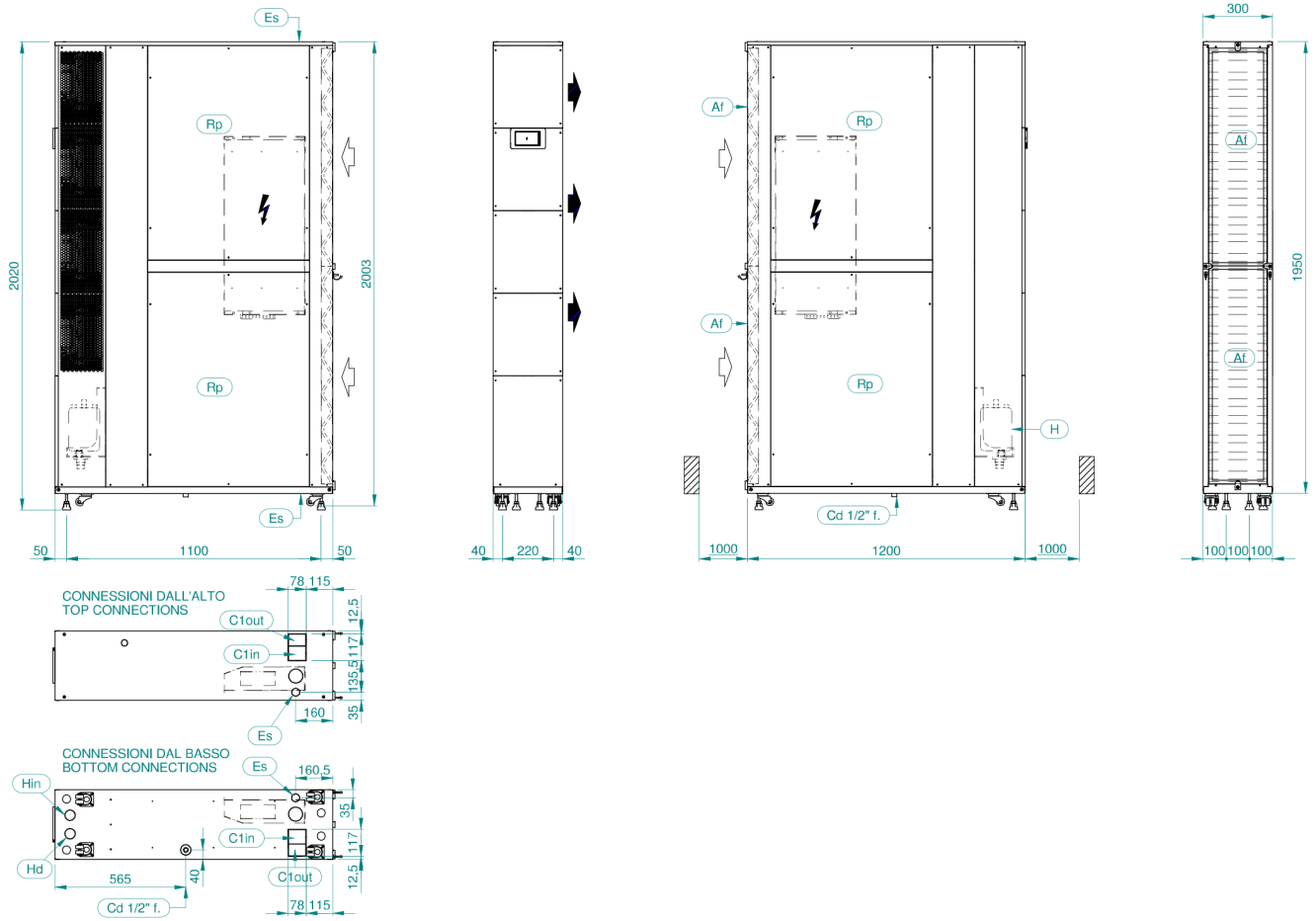

Warning! The air exhaust side is the one as seen looking at the unit from the top, orienting the unit according to the path of the air flow inside it.

---

## INSTALLATION TIPS

### PUTTING IN PLACE

- Coolblade units are perfectly balanced, but they are tall and slender and have their centre of gravity about halfway up, so care must be taken when handling and positioning them.
- Strictly comply with the clearance spaces indicated in the catalogue.
- Coolblade units are designed and made for interior use only. The hydraulic circuits are not provided with freeze protection.

### ELECTRICAL CONNECTIONS

- Always consult the attached wiring diagram, which provides all the instructions necessary for making the electrical connections.
- Electrical connections to be made for Coolblade units: it is possible to carry one or two (based upon the unit configuration) single-phase/three phases (depending on the unit size) power lines and connect both to the disconnect switch. For Coolblade CW-DW-DW it will be possible to choose which power supply to use through the disconnect switch-selector switch on the unit. For all the units if fitted with accessory DAA (Dual power supply with automatic changeover) will be possible to select the preferred line.
- For unit Coolblade DX: if the power supply comes from the external unit, connect it to just one of the incoming lines available on the Coolblade DX unit.
- Power up the COOLBLADE units.
- Before accessing the internal parts of the Coolblade CW-DW-DX unit, power it down by turning the six-pole selector switch, which also acts as disconnect switch, to position "0".
- Before accessing the internal parts of the Coolblade ED+, power it down by turning the main disconnection switch (Placed on the back behind the filters) to position "0".
- The power supply line must be protected in accordance with current regulations.

### HYDRAULIC AND REFRIGERANT CONNECTIONS

- If the hydraulic connections are carried out from the bottom, thoroughly vent the hydraulic system, with pumps switched off, by operating the air valves of the Coolblade units. This procedure is particularly important because even small air bubbles can cause reduced performance of the finned pack heat exchanger of the Coolblade units. If the hydraulic connections are carried out from the top, the air vent must be positioned by the customer on the highest point of the system.
- Make the hydraulic circuit with inclusion of the typical components used in closed hydraulic circuits (for example, expansion vessel, flow switch, storage tank, air valves, shutoff valves, anti-vibration couplings, etc.).
- Make the refrigerant connections strictly following the instructions provided with the installation, operation and maintenance manual, in particular as regards the braze-welding, cleaning, vacuum and charging operations.

### START-UP AND MAINTENANCE

- Strictly follow the instructions given in the operation and maintenance manual. These operations must in any case be carried out by qualified persons.



---

---

